

Installation Guide

GE LED Plug in G24Q Vertical

LED18ABG24Q-V/3CC5



BEFORE YOU BEGIN

Read these instructions completely and carefully



WARNING

- Risk of fire or electric shock. Disconnect power at fuse or circuit breaker before installing or servicing.
- Risk of fire or electric shock. Installation and circuit modification must be performed only by a qualified electrician.
- To prevent wiring damage or abrasion, do not expose wiring to edges of sheet metal or other sharp objects.
- Do not make or alter any open holes in an enclosure of wiring or electrical components during installation.
- This lamp only operates on electronic ballasts or direct wiring. If the lamp does not light when the luminaire is energized, remove lamp from luminaire and contact lamp manufacturer or qualified electrician.
- This lamp is designed for 26w, 32w or 42w ballasts.
- This lamp is designed to work with G24q or GX24q socket only.
- This lamp is not intended for use with emergency exits.
- This lamp is not for use with dimmers.

These products are intended to be used in dry or damp locations.

Save These Instructions

Use only in the manner intended by the manufacturer. If you have any questions, contact the manufacturer.

Prepare Electrical Wiring



Electrical Requirements

The fixture must be supplied with 120/277VAC 60Hz or electronic ballasts.

Not compatible with magnetic ballasts.



Grounding Instructions

The grounding and bonding of the overall system shall be done in accordance with National Electric Code(NEC) and local codes.

Replacement / Type A – If you want to simply install the lamp and use existing ballast.

TYPE A LAMP - Intended for direct substitution of a fluorescent lamp and operating from the integral ballast without any modifications to the fluorescent luminaire.

1. Switch off power to the fixture.
2. Ensure the light fixture is designed to accommodate **a 4-pin G24q or GX24q** fluorescent lamp before installing.
3. Remove the existing fluorescent lamps from the fixture and dispose of them properly based on local regulations.
4. Check the socket condition in the fixture. If damaged or corroded, replace it with a new one. **WARNING:** Sockets in poor condition may result in a bad electrical contact, base arcing, or other safety issues.
5. **Select wattage and CCT** using the slide switch on the lamp before installing.
6. Insert LED **4 pin** lamp(s). For horizontal application, rotate the lamps so the diffuser is facing towards the fixture opening. **NOTE:** In If the existing fixture supports the use of two lamps, be sure to use LED **4 pin** lamps in both sockets. Do not mix CFL and LED lamps together on the same ballast as the ballast may shutdown.
7. Restore power to fixture and check for proper operation.

WARNING-RISK OF FIRE. USE ONLY IN PLACE OF FLUORESCENT LAMPS SPECIFIED ON LABEL. DIRECT REPLACEMENT FOR 26W/32w/42w G24q or GX24q CFL LAMPS ONLY. FOR USE ONLY WITH COMPATIBLE ELECTRONIC BALLASTS.

See ballast compatibility list at: www.gelighting.com/led-4pin-ballast-compatibility

Installing LED lamp on incompatible ballast voids the warranty and may disable the LED lamp and/or ballast.

Do not use on series connected dual-lamp ballasts.

THIS LAMP ONLY OPERATES ON ELECTRONIC BALLASTS. IF THE LAMP DOES NOT LIGHT WHEN THE LUMINAIRE IS ENERGIZED, REMOVE LAMP FROM LUMINAIRE AND CONTACT LAMP MANUFACTURER OR QUALIFIED ELECTRICIAN

CAUTION-IF THE LAMP OR LUMINAIRE EXHIBITS UNDESIRABLE OPERATION, SUCH AS FLICKERING OR BUZZING, IMMEDIATELY TURN OFF POWER, REMOVE LAMP FROM LUMINAIRE AND CONTACT MANUFACTURER

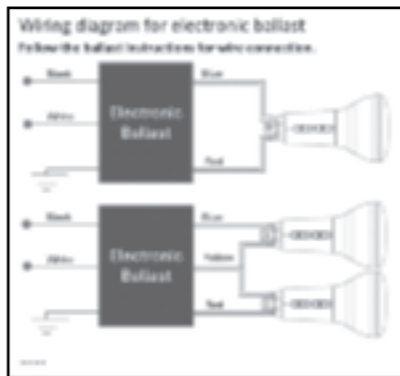

Ballast compatibility

The following ballasts are compatible with LED18ABG24Q-V/3CC5.

Ballast manufacturer	Model name	Ballast manufacturer	Model name
General Electric	GEC242-MVPS-SE	Osram Sylvania	QTP 2x26CF/UNV DM
General Electric	GEC242-MVPS-3W	Osram Sylvania	QTP 2x26/32/42CF/UNV TM
General Electric	GEC226-MVPS-3W	Universal Triad	C2642UNVME
Philips Advance	VEZ-1T42-M2-BS	Universal Triad	C242UNVME
Philips Advance	ICF-2S42-M2-LD	Lutron	EC3DT442KU2S
Philips Advance	REZ-1T42-M2-LD	Lutron	EC3DT442KU1
Philips Advance	IZT-2S26-M5-LD	Lutron	EC3DT4MWKU2S
Philips Advance	ICF-2S26-H1-LD	Robertson	M226CQMVDWCE
Philips Advance	ICF-2S26-M1-BS	Robertson	RED1L10-120H
Philips Advance	IZT-2S26-M5-BS	Pony	NPY-120-226-CFL

Direct Wire / Type B – If you want bypass the ballast and re-wire to run on line voltage.

TYPE B LAMP – Intended for operation in luminaires with traditional fluorescent-type lampholders wired directly to the branch circuit. This includes both factory-wired luminaires as well as those converted for this purpose under a retrofit program.

To protect against future misapplication, GE Lighting recommends installing an in-line fuse; Type 2AG, rated at 2 Amp, 350Volts, Littelfuse part number 0209002 MXP or equivalent.

1. Switch off power to the fixture.
2. Ensure the light fixture is designed to accommodate a 4-pin G24q or GX24q fluorescent lamp before installing.
3. Remove the existing fluorescent lamps from the fixture and dispose of them properly based on local regulations.
4. Open the ballast compartment and remove the ballast. Cut the ballast supply and load wires (refer to diagram below).
5. Check the socket condition in the fixture. If damaged or corroded, replace it with a new one. **WARNING:** Sockets in poor condition may result in a bad electrical contact, base arcing, or other safety issues.
6. Connect the recommended fuse and fuse holder (not supplied) to the black (hot) wire from the mains.
7. Connect all the lamp holder leads on one side together and connect to the other side of the recommended fuse with suitable wire.
8. Connect all the lamp holder leads on the other side together and connect to the white or neutral wire from the mains.

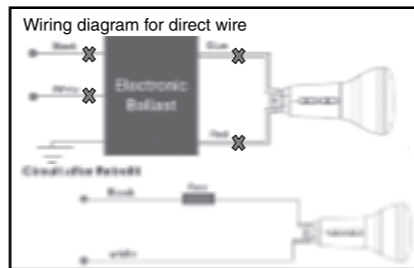

9. Replace the ballast/wiring area cover, ensure no wires are pinched between the cover and fixture.
10. Apply warning label in an easy to see location to ensure the user understands the system now uses LED Type B lamps and the use of CFL lamps may result in damage or injury.
11. Select wattage and CCT using the slide switch on the lamp before installing.
12. Insert LED 4 pin lamp(s). For horizontal application, rotate the lamps so the diffuser is facing towards the fixture opening.
13. Restore power to fixture and check for proper operation.

FCC STATEMENT:

Type A Installation

This device complies with Part 18 of the FCC Rules. Operation is subject to the following two conditions:

1. This device may not cause harmful interference.
2. This device must accept any interference received, including any interference that may cause undesired operation.

Any changes or modifications that are not expressly approved by the manufacturer could void the user's authority to operate the equipment.

NOTE: This product complies with Part 18 of the FCC Rules but may cause interference to radios, televisions, wireless telephones, and remote controls. Avoid placing this product near these devices. If interference occurs, move the product away from the device or plug either into a different outlet. Do not install this product near maritime safety equipment or other critical navigation or communication equipment operating between 0.45-30 MHz

Type B Installation

This device complies with Part 15 of the FCC Rules. Operation is subject to the following two conditions:

1. this device may not cause harmful interference, and
2. this device must accept any interference received, including interference that may cause undesired operation.

Any changes or modifications not expressly approved by the manufacturer could void the user's authority to operate the equipment.

NOTE: This equipment has been tested and found to comply with the limits for a Class B digital device, pursuant to Part 15 of the FCC Rules. These limits are designed to provide reasonable protection against harmful interference in a residential installation. This equipment generates, uses and can radiate radio frequency energy and, if not installed and used in accordance with the instructions, may cause harmful interference to radio communications. However, there is no guarantee that interference will not occur in a particular installation. If this equipment does cause harmful interference to radio or television reception, which can be determined by turning the equipment off and on, the user is encouraged to try to correct the interference by one or more of the following measures: reorient or relocate the receiving antenna, increase the separation between the equipment and receiver, connect the equipment into an outlet on a circuit different from that to which the receiver is connected, or consult the dealer or an experienced radio/TV technician for help.

GE Lighting, a Savant company

1-800-435-4448 • www.gelighting.com

GE IS A TRADEMARK OF GENERAL ELECTRIC COMPANY. USED UNDER TRADEMARK LICENSE.
©2024 GE LIGHTING, A SAVANT COMPANY

INFORMATION PROVIDED IS SUBJECT TO CHANGE WITHOUT NOTICE. ALL VALUES ARE DESIGN OR TYPICAL VALUES WHEN MEASURED UNDER LABORATORY CONDITIONS.

PK-00113540-2