

GE ConstantColor™ CMH SuperMini 20W & 35W

LAMP TECHNOLOGY

ConstantColor™ CMH lamps combine HPS technology (providing stability, efficiency & uniformity) and Metal Halide Technology (providing bright white quality light) to produce highly efficient light sources with good colour rendering and consistent colour performance through life. This is achieved by using the ceramic arc tube material from the Lucalox™ lamp, which minimises the chemical changes inside the lamp through life.

GE has now miniaturized this technology resulting in the CMH Supermini, highly efficient 20 and 35 Watt lamps with the light quality and colour stability associated with Ceramic Metal Halide, in a size comparable to tungsten halogen capsule lamps, thus offering new energy saving options to the lighting designer and end user.

FEATURES

- Consistent colour over life
- Excellent colour uniformity lamp to lamp
- Bright light – in a very compact size
- Excellent colour rendition
- High reliability due to 3 part design
- Up to 87 Lumens per Watt (LPW) efficacy
- Long Life
- UV control
- 35W available in two colour temperatures
- Robust GU6.5 base

APPLICATION AREAS

- Retail
- Offices
- Outdoor Lighting
- Display Cabinet
- Hotels



Watts	Colour	Operating position	Length mm	Product Description	Cap	Colour	Initial Lumens	Rated Average Life Hrs.	Pack Qty	Product Code
20	WDL	U	52 max	CMH20/T/UVC/830/GU6.5	GU6.5	830	1615	12.000	12	40399
35	WDL	U	52 max	CMH35/T/UVC/930/GU6.5	GU6.5	930	3400	10.000*	12	88656
35	NDL	U	52 max	CMH35/T/UVC/942/GU6.5	GU6.5	942	3400	12.000*	12	88657

* Initial rating at time of launch. Testing continues to establish final design life.



General Information

	40399	88656	88657
Product code	40399	88656	88657
Nominal wattage	20 W	35 W	35 W
Format	Single Ended	Single Ended	Single Ended
Bulb type	T4	T4	T4
Bulb diameter (nominal)	12 mm	12 mm	12 mm
Bulb material	UVC quartz	UVC quartz	UVC quartz
Bulb finish	clear	clear	clear
Arc Gap	3.45 mm	4.65 mm	4.65 mm
Base	GU6.5	GU6.5	GU6.5

Operating Conditions

Burning Pos'n	Universal	Universal	Universal
Luminaire	Enclosed	Enclosed	Enclosed

Electrical Characteristics

power	20 W	39 W	39 W
voltage	95 V	90 V	95 V
current	0.21 A	0.42 A	0.42 A
Max ignition voltage	4kV	4kV	4kV
Min ignition voltage	3kV	3kV	3kV
Extinction voltage	80%	90%	90%

Photometric characteristics

lumens	1615	3400	3400
CCT	3000 K	3000 K	4000 K
CCx	0.434	0.440	0.377
CCy	0.400	0.401	0.366
CRI Ra	81+	88	90
Luminous efficacy	81 LPW	87 LPW	87 LPW

Starting and Warm-up Characteristics

Time to start @ 10°C, sec	<5	<5	<5
Time to start @ -30°C, sec	<15	<15	<15
Hot restart time, min	<4	<5	<5
Warm-up to time to 90% lumen output	<1.5	<1.5	<1.5

Maximum Operating Condition

Max bulb temperature ¹	400 °C	550 °C	550 °C
Max base temperature ²	250 °C	350 °C	350 °C

¹ Measured in horizontal orientation on T4 quartz capsule, with thermocouple attached directly above the centre of the arc tube.

² Measured on quartz capsule pinch, immediately above the GU6.5 ceramic cap.

Dimensions

See diagram opposite

A	52 mm max.	52 mm max.	52 mm max.
B	12 mm nom.	12 mm nom.	12 mm nom.
	13 mm max.	13 mm max.	13 mm max.
C	30 mm nom.	30 mm nom.	30 mm nom.

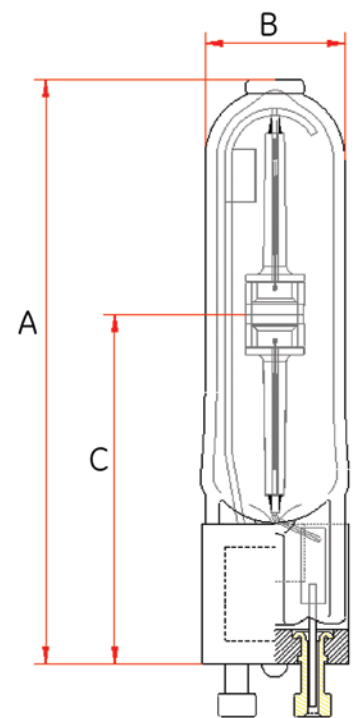

SPECTRAL POWER DISTRIBUTION

Spectral Power Distribution curves are given in the following diagrams

CMH20W SuperMini 830

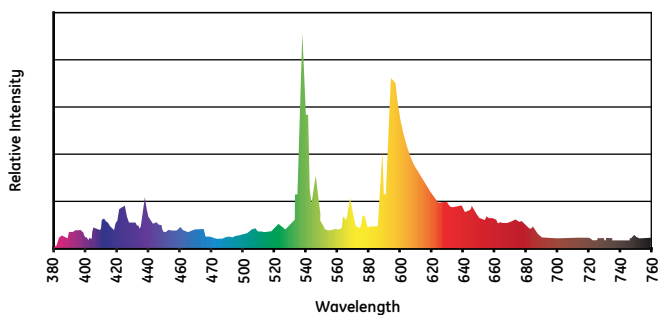

CMH35W SuperMini 930

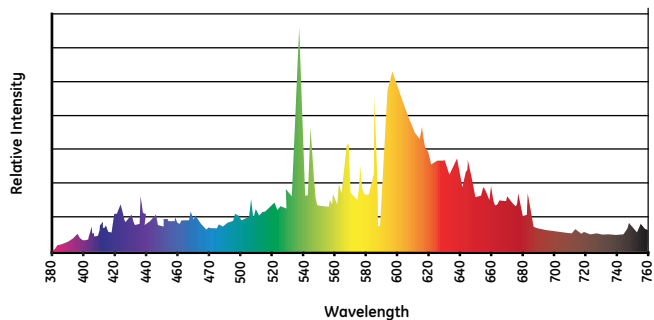

CMH35W SuperMini 942

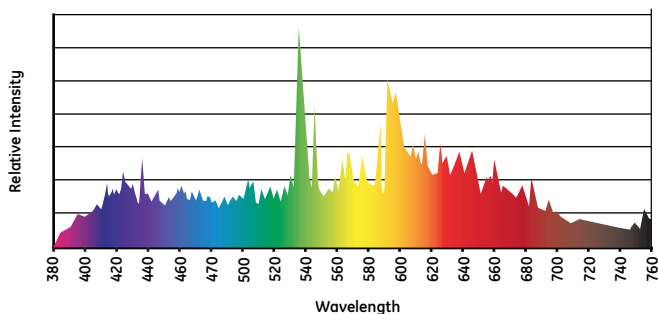

DISTRIBUTION OF LUMINOUS INTENSITY

The following diagrams show polar light intensity curves for lamp base-up orientation

CMH20T/U830GU6.5

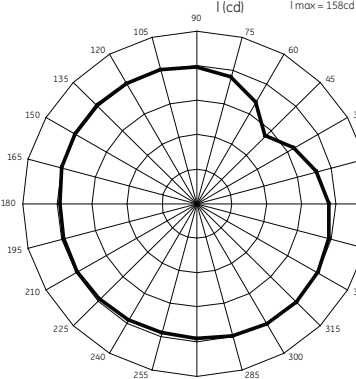

CMH20T/U830GU6.5

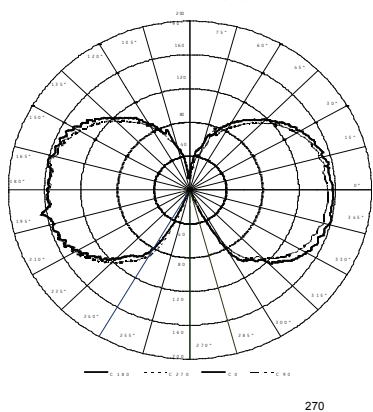

CMH35T/U930GU6.5

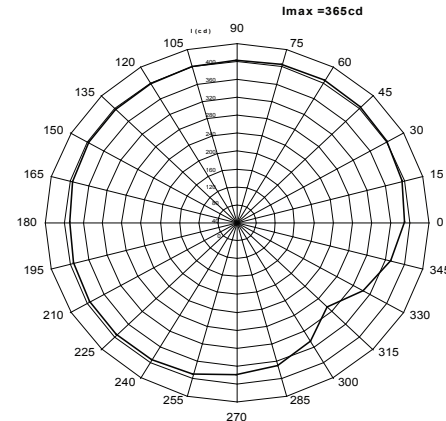

CMH35T/U930GU6.5

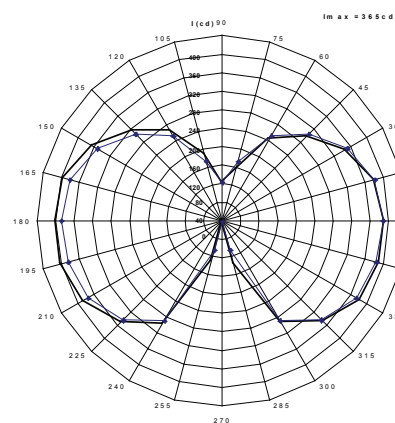

CMH35T/U942GU6.5

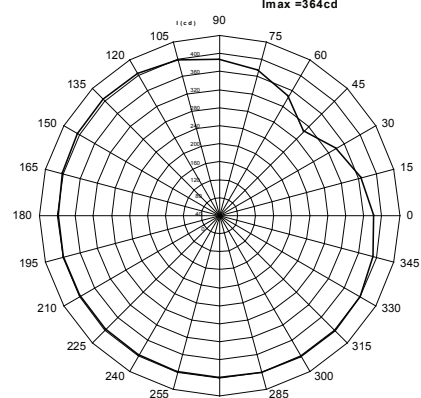

CMH35T/U942GU6.5

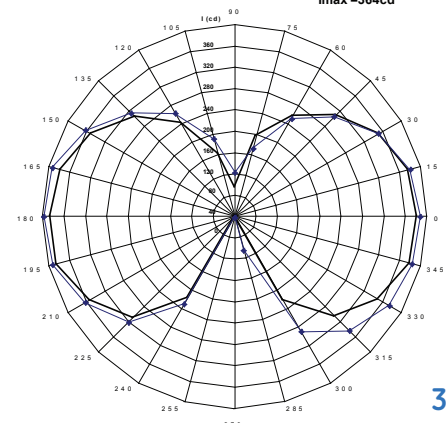

LAMP LIFE

Life survival graphs are shown for statistically representative batches of lamps operated under controlled nominal conditions with an 11 hours per start switching cycle. The declared lamp life is the median life, which is when 50% of the lamps from a large sample batch would have failed. Lamp life in service will be affected by a number of parameters, such as supply voltage variation, switching cycle, operating position, mechanical vibration, luminaire design and control gear. The information is intended to be a practical guide for comparison with other lamp types. The determination of lamp replacement schedules will depend upon the acceptable reduction in illuminance and the relative costs of spot and group replacement.

Note: The representative curves are taken in Vertical Base Up position. Life performance can greatly increase in Horizontal Burning position.

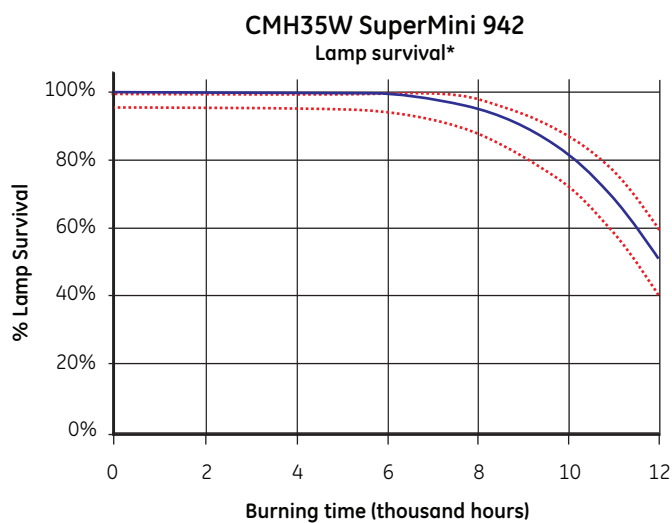
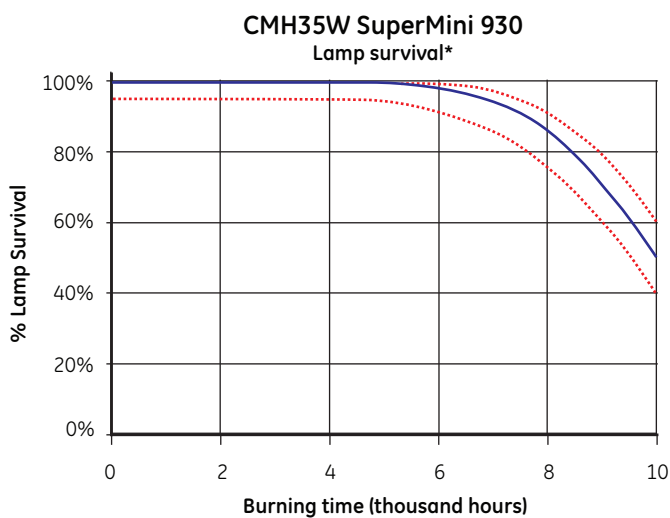
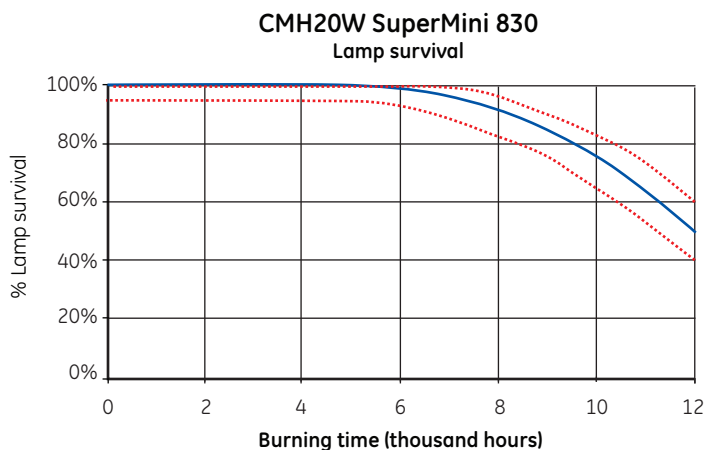

* Initial rating at time of launch. Testing continues to establish final design life.

LUMEN MAINTENANCE

Lumen maintenance graphs show light output performance through life for statistically representative batches of lamps operated under controlled nominal conditions with an 11 hours per start switching cycle.

A common characteristic for all metal halide lamps is a reduction in light output and a slight increase in power consumption through life. Consequently there is an economic life at which lamp efficacy falls to a level when lamps should be replaced to restore design illumination levels. Where a quantity of lamps are installed within an area, consideration should be given to a group lamp replacement programme to maintain uniform illumination levels.

Curves represent operating conditions for an 11 hours per start switching cycle, but less frequent switching will improve lumen maintenance.

Note: The representative curves are shown for Vertical Base-Up lamp orientation unless otherwise specified. Lumen maintenance performance improves when operated in the Horizontal burning position.

CMH20W SuperMini 830
Lumen Maintenance

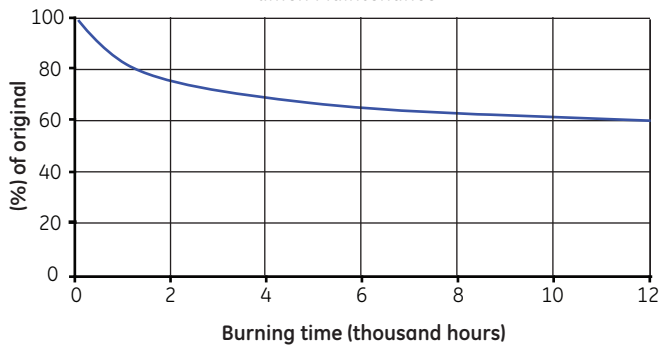

CMH35W SuperMini 930
Lumen Maintenance

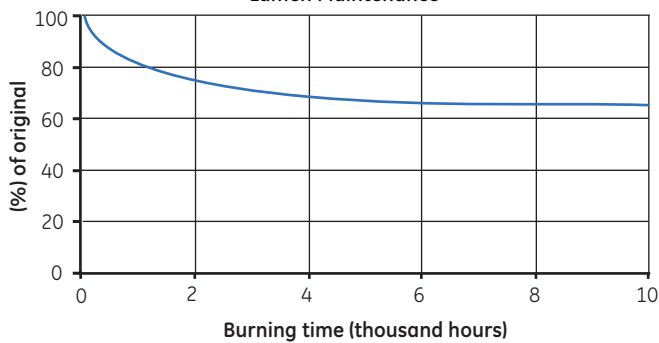

CMH35W SuperMini 942
Lumen Maintenance

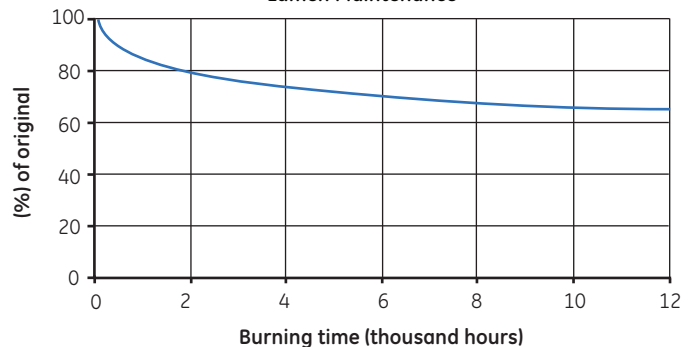

WARM-UP CHARACTERISTICS

During the warm-up period immediately after starting, lamp temperature increases rapidly evaporating mercury and metal halide dose in the arc tube. Lamp electrical characteristics and light output stabilise in less than 4 minutes. During this period light output increases from zero to full output and colour approaches the final visual effect as each metallic element becomes vaporised.

Typical Warm-up CMH 20W SuperMini

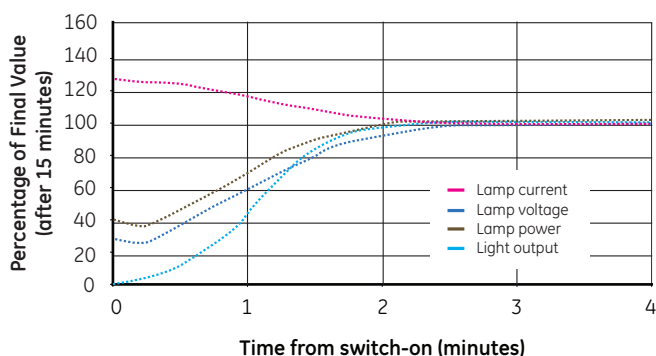

Typical Warm-up CMH 35W SuperMini

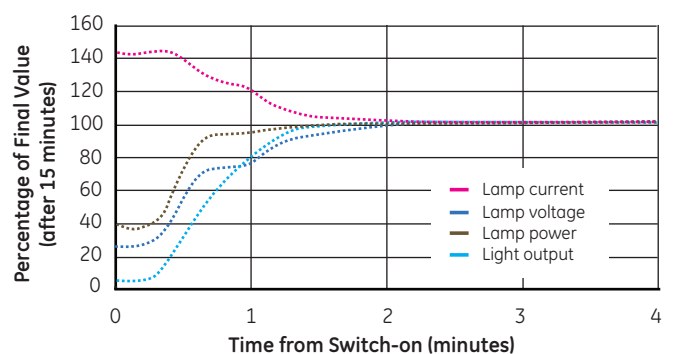

DIMMING

In certain cases, dimming may be acceptable, subject to further testing. Contact your GE representative for more information. Large changes in lamp power alter the thermal characteristics of the lamp resulting in lamp colour shift and possible reduction in lamp survival.

FLICKER

Suitable electronic ballasts for ConstantColor™ CMH lamps provide square wave operation in the 70-400 Hz range and eliminate perceptible flicker.

LAMP END OF LIFE CONDITIONS

The principal end-of-life failure mechanism for CMH lamps is arc tube leakage into the outer jacket. High operating temperature inside the arc tube causes metal halide dose material to gradually corrode through the ceramic arc tube wall, eventually resulting at normal end-of-life in leakage of the filling gas and dose. Arc tube leakage into the outer jacket can be observed by a sudden and significant lumen drop and a perceptible colour change (usually towards green).

The above situation can be accompanied by the so-called rectification phenomena. This occurs where a discharge is established between two mount-frame parts of different material and/or mass, causing asymmetry in the electrical characteristic of the resulting discharge current. Rectification can lead to overheating of the ballast, therefore to maintain safety use electronic ballast or system which can shut itself off if ballast overheating occurs.

END OF LIFE CYCLING

A possible condition can exist at end-of-life whereby lamp voltage rises to a value exceeding the voltage supplied by the control gear. In such a case the lamp extinguishes and on cooling restarts when the required ignition voltage falls to the actual pulse voltage provided by the gear. During subsequent warm-up the lamp voltage will again increase, causing extinction. This condition is known as end-of-life cycling. With electronic ballasts, cycling is unlikely.

Normally cycling is an indication that lamp end-of-life has been reached, but it can also occur when lamps are operated above their recommended temperature. Lamp voltage at 100 hours life should not increase by more than 5V when operating in the luminaire, when compared to the same lamp operating in free-air. A good luminaire design will limit lamp voltage rise to 3V.

It is good practice to replace lamps that have reached end-of-life as soon as possible after failure, to minimise electrical and thermal stress on control gear components.

UV AND DAMAGE TO SENSITIVE MATERIALS

The wall of the bulb, which is produced with specially developed 'UV Control' material, absorbs potentially harmful high energy UV radiation emitted by the ceramic arc tube.

The use of UV control material together with an optically neutral front glass cover allows the lamp to significantly reduce the risk of discolouration or fading of products. When illuminating light-sensitive materials or at high light levels, additional UV filtration is recommended. Luminaires should not be used if the front glass is broken or missing.

It is recommended that a safety interlock switch is incorporated into the luminaire to prevent operation when the luminaire is opened.

Although PET determines limits of human exposure to lamp UV, the risk of fading of merchandise due to UV can be quantified by a Damage Factor and a Risk of Fading. The risk of fading is simply the numerical product of the illuminance, exposure time and damage factor due to the light source.

Finally the selection of luminaire materials should take into consideration the UV emission. Current UV reduction types on the market are optimised for UV safety of human eye and skin exposure. However, luminaire materials may have different wavelength dependent response functions. Designers must take account of emission in each of the UV-A, UV-B and UV-C spectral ranges as well as material temperatures when designing luminaires.

Typical values for UV-A, UV-B and UV-C range radiation can be found in the table below.

UV AND DAMAGE TO SENSITIVE MATERIALS

UV PET performance

1. Data from bare lamp

	UV-C ¹	UV-B ¹	UV-A ¹	UVC/UVA	UVB/UVA	E _{eff} ²	PET (h)	Risk Group
	200-280 nm	280-315 nm	315-400 nm					
CMH 20W 830	0.053	0.091	11.46	0.005	0.008	1.73	10	Exempt
CMH 35W 930	0.016	0.031	6.05	0.003	0.005	0.58	29	Exempt
CMH 35W 942	0.039	0.062	16.26	0.002	0.004	1.23	14	Exempt

2. Data from lamp operated in typical glass-fronted luminaire

	UV-C ¹	UV-B ¹	UV-A ¹	UVC/UVA	UVB/UVA	E _{eff} ²	PET (h)	Risk Group
	200-280 nm	280-315 nm	315-400 nm					
CMH 20W 830	0.0010	0.0012	2.41	0.0004	0.0005	0.01	1648	Exempt
CMH 35W 930	0.0003	0.0001	4.55	0.0001	0.0000	0.01	1622	Exempt
CMH 35W 942	0.0003	0.0001	12.25	0.0000	0.0000	0.02	761	Exempt

¹ $\mu\text{W} / (\text{cm}^2) / 500 \text{ Lux}$

² mW / klm

INFORMATION FOR LUMINAIRE DESIGN

CMH 20W and CMH 35W have optimum performance on electronic gear.* This provides many advantages:

- Flicker free light output
- Well controlled electronic ignition process
- Simple wiring for fixtures due to elimination of ignitor and PFC capacitor
- Reduces fixture weight
- Automatic sensing of failed lamps and shutdown
- Lower overall system power consumption

* For details of approved electronic ballasts for ConstantColor™ CMH lamps please consult your GE representative. CMH 20W is designed only for operation on electronic gear

CIRCUIT DIAGRAM

electronic ballast
LH: Lamp Holder
E: Electronic Gear

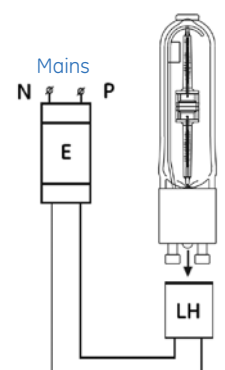

CONTAINMENT REQUIREMENT

ConstantColor™ CMH lamps operate above atmospheric pressure, therefore a very small risk exists that the lamp may shatter when the end of life is reached. Though this failure mode is unlikely, containment of shattered particles is required as prescribed by IEC 62035.

ConstantColor™ CMH SuperMini lamps should only be used in a suitable enclosed luminaire with front cover glass capable of containing the fragments of a lamp should it shatter.

CONTROL GEAR AND ACCESSORIES

Electronic Ballasts

A range of GE electronic ballasts have been introduced to complement the 20 and 35W ConstantColor™ Ceramic Metal Halide lamps. Power controlled electronic ballasts suitable for operation of Ceramic Metal Halide lamps are available from various gear manufacturers. Please consult GE for up to date details of approved ballast types.

Advantages are:

- Good regulation against supply voltage variation
- Improved lamp colour consistency
- Elimination of lamp flicker
- Reduced weight of control gear
- Reduced electrical power losses
- Ballast noise reduced/eliminated
- Single piece compact unit
- Reduced wiring complexity in the luminaire



SAFETY WARNINGS

The use of these products requires awareness of the following safety issues:

WARNING

- Risk of electric shock - isolate from power supply before changing lamp
- Strong magnetic fields may impair lamp performance and worst case can lead to lamps shattering

Use only in ENCLOSED FIXTURES to avoid the following:

- Risk of fire
- A damaged lamp emits UV radiation which may cause eye/skin injury
- Unexpected lamp shattering may cause injury, fire, or property damage

CAUTION

- Risk of burn when handling hot lamp
- Lamp may shatter and cause injury if broken
- Arc tube fill gas contains Kr-85

Always follow the supplied lamp operation and handling instructions.