

HID Ballast Application Guide



GE imagination at work

Table of Contents

1	Introduction To HID Lighting	3
2	HID Lamp Types	4
2.1	Mercury Vapor (MV).....	5
2.2	High Pressure Sodium (HPS).....	6
2.3	Quartz Metal Halide (QMH).....	6
2.4	Pulse Start Quartz Metal Halide.....	7
2.5	Ceramic Metal Halide	8
3	HID Ballast Types	8
3.1	Electromagnetic Ballasts (EM)	9
3.1.1	Reactor (R).....	9
3.1.2	High Reactance Autotransformer (HX).....	10
3.1.3	Constant Wattage Autotransformers (CWA).....	10
3.1.4	Constant Wattage Isolated (CWI).....	11
3.1.5	Magnetic Regulator.....	11
3.2	Electronic Ballasts.....	11
3.2.1	Low Frequency Lamp Operation	11
3.2.2	High Frequency.....	13
4	Electromagnetic Ballast Applications	13
4.1	Ballast Casing Designs.....	13
4.1.1	Core & Coil	13
4.1.2	F-Can	13
4.1.3	Potted Core & Coil	14
4.2	GE Ballast Kits	14
4.2.1	Power Factor Capacitors.....	14
4.2.2	Ignitors	15
5	Electronic Ballast Applications	15
5.1	Pulse ratings and applicable lamps.....	15
5.2	Power Factor Correction.....	15
5.3	Transient Protection.....	16
5.4	Hi-Potting Ballast with Internal Transient Protection	16
5.5	Output Short Circuit	17
5.5.1	HID Ballast Output Short Circuit Guide.....	17
5.5.2	Differential Output Shorts (Output Lead to Output Lead)	17
5.5.3	Common Mode Output Shorts (Output Lead to Ground).....	17
5.6	Remote Mounting.....	18
5.7	Dimming Applications.....	19
5.7.1	Power Up at 100%.....	19
5.7.2	Full Light Level Cycling	20
5.7.3	Minimum Dimming Level.....	20
6	Temperature effects on Lamp and Ballast.....	21
6.1	Heat.....	21
6.2	Normal Temperature Limits:	21
6.3	Thermal Protection.....	21

6.4	Low Ambient Temperature (Cold)	22
6.5	Other Environmental Conditions	22
7	Standard and Regulatory Ratings	22
7.1	UL, CSA, FCC, IEC, NEMA, etc.	22

Follow all safety and operating instructions when handling, installing, and operating lamps, ballasts, and other lighting products.

IMPORTANT NOTICE: The information in this document is believed to be accurate, but GE makes no warranty or guarantee (and our employees and representatives are not authorized to make any such warranty or guarantee), express or implied, (i) that the analyses, recommendations, performance, and results described herein will be obtained under end-use conditions, (ii) as to the effectiveness or safety of any design incorporating GE materials, products, recommendations or advice, or (iii) regarding the accuracy or completeness of the information, including the assumptions and formula on which such information is based. Applications and conditions of use are many and varied and beyond GE’s control, and GE cannot possibly have the same degree of knowledge that the purchaser has with respect to the design of its equipment and the conditions of its use or as to the suitability of GE’s materials, products, recommendations, or advice for the purchaser’s particular use. Therefore, each purchaser/user/reader bears full responsibility for making its own determination as to the suitability and safety of GE’s materials, products, recommendations, or advice for its own particular use and to assume the responsibility for that determination. Each such entity/person must identify and perform all tests and analyses necessary to assure that its finished parts incorporating GE material or products will be safe and suitable for use under end-use conditions.

1 Introduction To HID Lighting

The term High Intensity Discharge or HID describes lighting systems that produce light through an electrical discharge which typically occurs inside a pressurized arc tube between two electrodes. In general, these systems feature long life, high light output for the size of the lamp and increased efficiency compared to fluorescent and incandescent technologies. HID lamps are named by the type of gas and metal contained within the arc tube. There are five different families of HID: Mercury Vapor, High Pressure Sodium, Quartz Metal Halide, Pulse Start Quartz Metal Halide, and Ceramic Metal Halide.

HID lamps come in various shapes and types, such as elliptical and tubular. The lamp bases come in various shapes and types as well, such as screw base, double ended, bi-pin and many others. See the lamp catalog for more information.

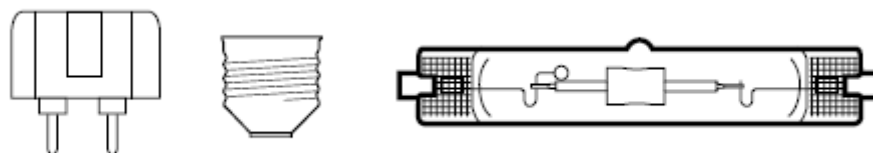

Figure 1: Bi-Pin, Screw and Double Ended Base Types

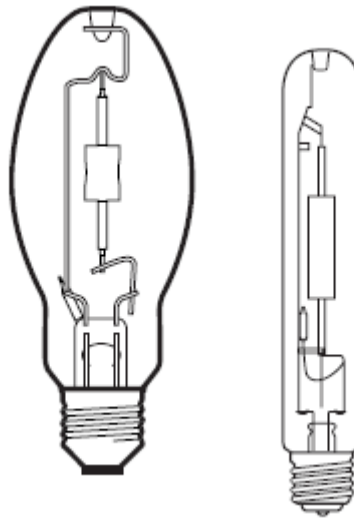

Figure 2: Elliptical and Tubular HID Lamps

HID lamps require a ballast to operate. Typically, the HID ballast (sometimes with the addition of a capacitor and igniter) serves to start and operate the lamp in a controlled manner.

HID lamps take several minutes to warm-up. Full light output is reached after the arc tube temperature rises and the metal vapors reach final operating pressure. A power interruption or voltage drop will cause the lamp to extinguish. Before the lamp will re-light, it must cool to the point where the lamp's arc will restrike.

2 HID Lamp Types

High Intensity Discharge lamps, as their name implies, produce a high level of light for their physical size by means of an electrical discharge. A controlled high intensity arc is maintained between two electrodes inside of a glass or ceramic tube, which is filled with gas and metal vapors.

The following chart summarizes the operating characteristics of HID lamps. Each lamp's main benefits and characteristics are described below.

*Data is typical of GE lamps sold in America

Characteristic	Mercury Vapor	High Pressure Sodium	Quartz Metal Halide Probe-Start	Quartz Metal Halide Pulse-Start	Ceramic Metal Halide
Lumens per watt	50-60	90-140	80-115	80-115	80-100
Lumen Maintenance Percent (%)	50-91%	79-98%	55-80%	70-90%	70-90%
Lamp Color Temperature (CCT)	3300- 5700	1900- 2200	3000- 6000	3100 - 4200	3000- 4200
Lamp Color	Bluish-White	Gold	White	White	White
Lamp Start Up Time (minutes)	5-7	3-4	2-5	2-5	2-5
Restrike Time (minutes)	3-6	1-3	10-20	5 - 10	3-17
Rated Lamp Life (thousand hours)	12-24+	10-40	3-20	10-20	7.5-20
Minimum Starting temperature (C)	-30	-40	-30	-30	-30
Typical Wattage Range (W)	40-750	35-1000	32-2000	32-2000	20-400

2.1 Mercury Vapor (MV)

Mercury Lamps are distinguished by their long life, low cost and bluish-white light output. They were originally developed as a more efficient light source than the familiar incandescent light bulb, for roadway and landscape lighting. They are the least efficient HID light sources at 50-60 Lumens Per Watt. Mercury Vapor lamps come in a variety of wattages ranging from 40-750 W, and have life ratings in the range of 12,000-24,000 hours. Mercury Vapor lamps must cool 3-6 minutes before being restarted.

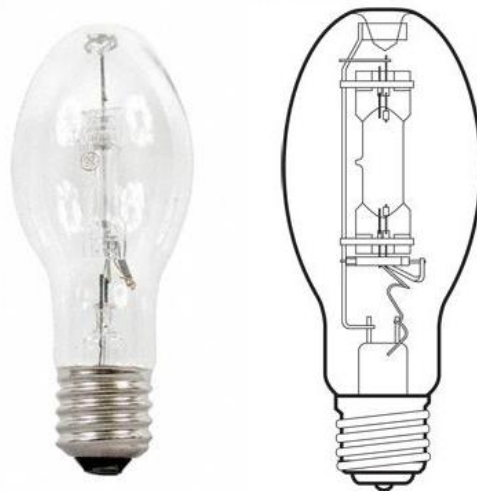

Figure 3: Mercury Vapor Lamps

2.2 High Pressure Sodium (HPS)

High Pressure Sodium lamps have an efficacy of 90-140 Lumens Per Watt, very long lamp life at 10,000 - 40,000 hours and a short warm up time of 3-4 minutes. They feature excellent lumen maintenance and quick re-strike times. They emit a golden light when operating and are typically used in streets and outdoor parking lots. HPS lamps make up the majority of HID lamps used in outdoor applications.



Figure 4: High Pressure Sodium Lamps

2.3 Quartz Metal Halide (QMH)

Metal Halide lamps have an efficacy of 80-115 lumens per watt and have a life between 10,000-20,000 hours. They are heralded because of the quality of light they produce. Specialty varieties of Metal Halide lamps are used in sporting stadiums and industrial applications where light quality is important. Probe start Metal Halide Lamps have an additional electrode, which assists the electromagnetic ballast in starting the lamp.



Figure 5: Quartz Metal Halide Lamps

2.4 Pulse Start Quartz Metal Halide

Pulse Start Quartz Metal Halide lamps have operating characteristics similar to those of Quartz Metal Halide lamps but have higher mean lumen ratings than standard Quartz Metal Halide lamps and better restrike characteristics over Probe Start.

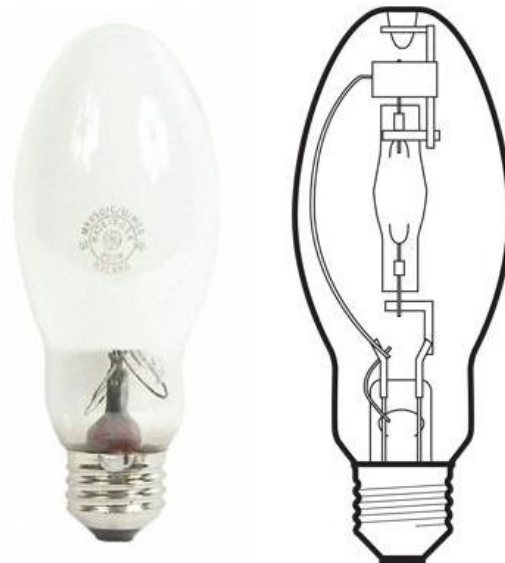

Figure 6: QMH Pulse Start Lamps

2.5 Ceramic Metal Halide

These lamps are a special type of Metal halide lamp, which utilize ceramics, rather than quartz as their arc tube enclosures. The ceramic material allows the lamp to have more consistent light output and color control over their life. Naturally, this improvement lends itself to applications where light quality and consistency are of paramount importance such as retail and grocery. Ceramic metal halide lamps feature up to 20,000 hour life, a wattage range of 20-400W, and 80-100LPW efficacy.

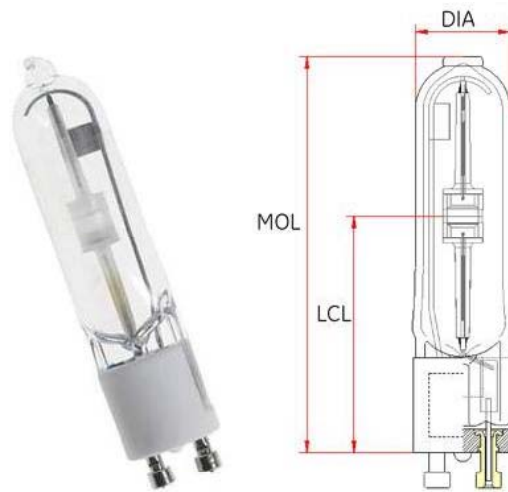

Figure 7: Ceramic Metal Halide Lamps

3 HID Ballast Types

HID lamps, like fluorescent lamps require a ballast to provide the proper starting voltage for the lamp and limit the operating current once the lamp is ignited. HID lamps have negative impedance, which means that the lamp draws more current than is required for it to operate. Without a ballast, running in this negative impedance condition, the lamp would self-destruct in a very short period of time.

HID ballasts are classified by the type of circuit they use: Reactor (R), High Reactance Autotransformer (HX), Constant wattage Autotransformer (CWA), Magnetic Regulator, or Electronic.

HID Ballasts are typically classified as High Power Factor (HPF) or Normal Power Factor (NPF). See the Power Factor Correction section for more information.

The following chart summarizes the different type of HID ballasts and describes their operating characteristics.

Characteristic	Linear Reactor	HX	Constant Wattage Autotransformer	Constant Wattage Isolated	Regulated Lag or Magnetic Regulator	Electronic
Regulation	No	No	Yes	Yes	Yes	Yes
Voltage input Variance +/-	5%	5%	10%	10%	10%	10%
Start / operate current	Starts high, goes lower.	High to lower	Starts Low, goes higher	Low to higher	Low to higher	
Wattage Control. % change for 1% voltage.	2.5	2.5	1.5	1.5	0.8	< 0.8
Voltage dip tolerance	7 - 25%	7 - 25%	10 - 50%	10 - 60%	25 - 60 %	
Power Factor	NPF or HPF	NPF or HPF	HPF	HPF	HPF	NPF or HPF
Ballast losses	Low	Low Med	Medium	Medium	High	Low
Relative size	Small	Small	Medium	Medium	Large	Small
Relative weight	Light	Light	Medium	Medium	Heavy	Light
Advantage	High efficiency	High efficiency	Good efficiency & good regulation	Good efficiency & good regulation	Best regulation for EM	Excellent Regulation & controllability
Cost	Lowest	Lowest	Medium	Medium	High	High

3.1 Electromagnetic Ballasts (EM)

Electromagnetic Ballasts use magnetic components to start and regulate the operation of a lamp. Inductors are used as the current limiting component in EM ballasts. Although the inductor is very good at regulating current, it causes a phase shift input of the current waveform creating a non-ideal power factor. Often times a Capacitor is used in Electromagnetic Ballasts to correct the power factor. A few of the most common Electromagnetic Ballasts are shown below.

3.1.1 Reactor (R)

The Reactor is the simplest, smallest, most efficient and most economical type of electromagnetic ballast. Reactor ballasts feature a simple design, which uses the Line Voltage to ignite the lamp. Reactors are generally used as Normal Power Factor devices. Their highest current draw occurs during starting, which must be allowed for in the capacity of the line. The line current can be lowered by using a capacitor across the line to achieve a High Power Factor of over 90 percent allowing more ballasts per circuit. This ballasts requires an ignitor to start the lamp.

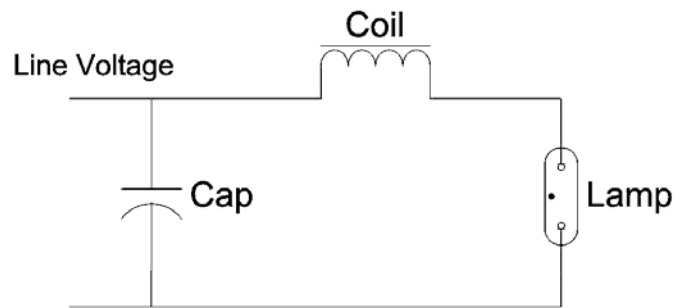

Figure 8: Simple Reactor Circuit

This reactor circuit is shown with the optional HPF capacitor. Required ignitor is not shown.

3.1.2 High Reactance Autotransformer (HX)

When the line voltage is insufficient to ignite the lamp using a reactor type ballast, a High Reactance Autotransformer can be used. It is very similar to the reactor ballast, but utilizes a two-coil design to step up the startup voltage to ignite the lamp. The coil

then acts to regulate the lamp current similar to the reactor ballast.

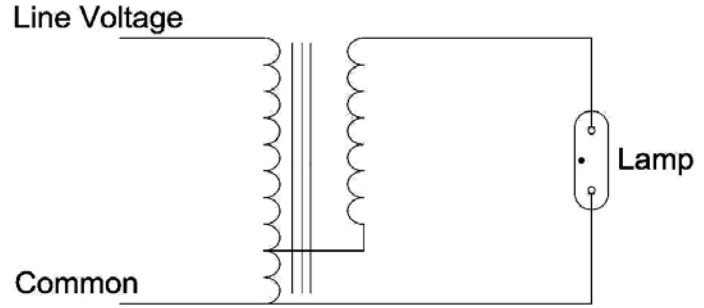

Figure 2: High Reactance Autotransformer

3.1.3 Constant Wattage Autotransformers (CWA)

Constant Wattage Autotransformer (CWA) ballast is the most popular HID ballast type. It provides an economical means of providing stabilized light output (lamp regulation) as opposed to the Magnetically Regulated circuit. The circuit consists of a high reactance autotransformer with a capacitor in series with the lamp resulting in a high power factor ballast. A CWA ballast also has a significantly lower dropout voltage (the voltage at which the lamp extinguish) than the lag types. The CWA ballast delivers better light output control also. In some CWA ballast designs a 10% variation in supply voltage will vary the lamp wattage and light output by only 5%. This circuit requires an ignitor for QMH pulse start, CHM and HPS.

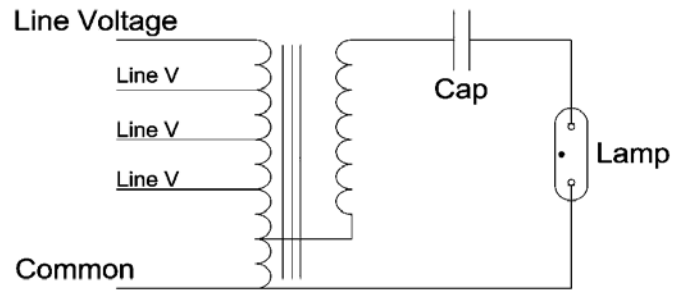

Figure 3: Simple CWA Circuit

Required ignitor is not shown.

3.1.4 Constant Wattage Isolated (CWI)

The Constant Wattage Isolated ballast is very similar to the CWA ballast, but the secondary coil in the CWI is isolated from the primary.

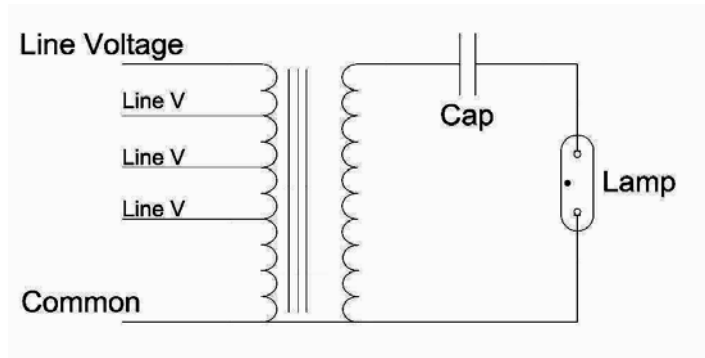

Figure 4 Simple CWI Circuit

Required ignitor is not shown.

3.1.5 Magnetic Regulator

Magnetically Regulated (Mag Reg) and Regulated Lag (Reg Lag) are another type of EM ballasts. They utilize a magnetic with three separate coils. One coil connects to a capacitor for increased Power Factor and to regulate current into the lamp coil. The lamp coil is isolated from the power supply. This circuit provides very good control over light output. In some ballast designs,

large changes in voltage cause very small changes in lamp wattage.

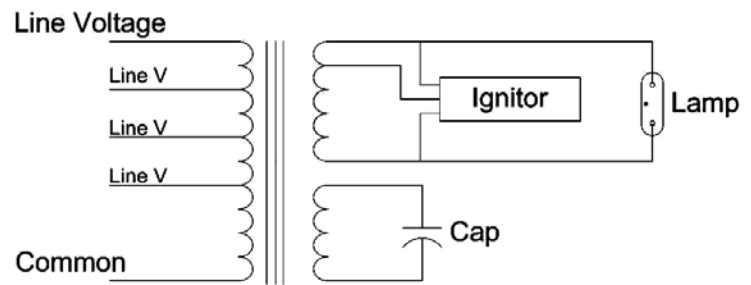

Figure 5: Simple Magnetically Regulated Circuit

This circuit can operate at a variety of line voltages by using the different Line V transformer tap locations.

3.2 Electronic Ballasts

Electronic Ballasts use solid-state electronic components to start and operate the ballasts. Electronic ballasts often use IC chips and feedback to implement better controls, and safety features into ballasts. Electronic ballasts typically operate much more efficiently than similar Electromagnetic Ballasts. A few other benefits are small size, lightweight, improved lumen maintenance, fault mode protection and better power regulation, which results in better color consistency.

3.2.1 Low Frequency Lamp Operation

GE analysis of internal and competitive HID lamps suggests that the most compatible driving waveform for an electronic ballast is a Low Frequency Square Wave (L.F.S.W.) with low higher order

harmonic content. L.F.S.W. has been long established as a dependable method of ballasting low Wattage HID lamps with significant industry standards support.

Analysis of lamp data has shown that there are limited operating bands between 1 kHz to 200 kHz in which an electronic ballast could operate a lamp wattage family without causing unacceptable arc instability due to Acoustic Resonance. Trend analysis of the A.R. maps show that this range extends well beyond 200 kHz. When the A.R. structure maps are overlaid there is no consistent frequency band, which can be identified as a stable location for ballast operation. There are large variations in the A.R. structure maps between multiple lamp vendors and from lamp type to lamp type or burn position. A.R. may cause visual annoyance, lamp cycling, shorten lamp life, and in extreme cases result in arc tube rupture.

Specific matched lamp – ballast high frequency systems can be stable, however they limit the extent that the individual members can be modified for future improvements. Additionally, there is no data on the long-term stability of the A.R. maps due to aging of the lamp. Future re-lamping may also create an unstable system due to changes in lamp arc tube geometry or manufacture.

Acoustic node map for a 400 Watt ceramic metal halide HID lamp

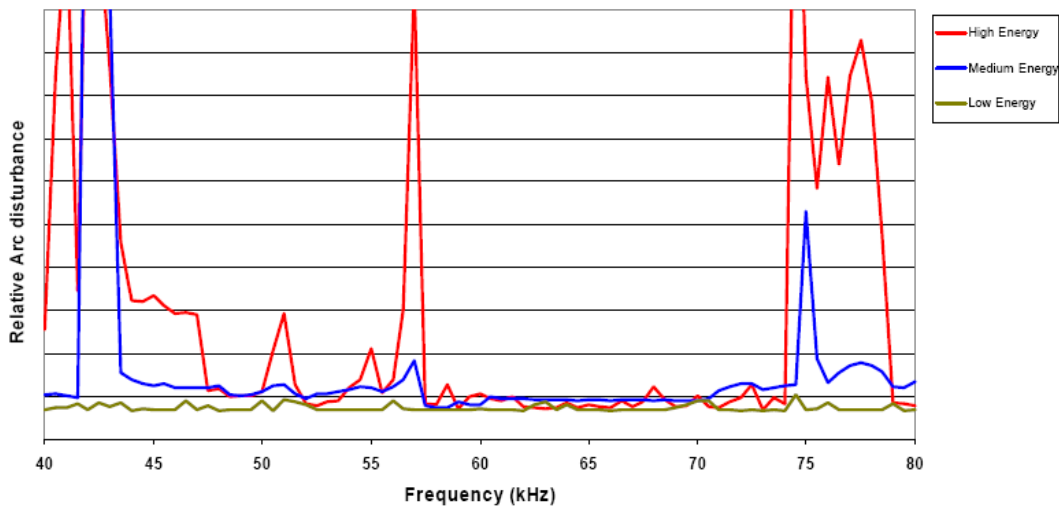

Lamp performance points to be considered:

Data on Electronic ballast technology has shown that it can greatly improve the lumen maintenance of HID lamps over traditional EM reactor or CWA ballast systems. However, no data are available to support improved lamp performance on High Frequency vs. Low Frequency Square Wave driving waveforms

Conclusions:

GE recommends operation of its high wattage CMH® and PulseArc® QMH HID lamps on electronic ballasts that use a Low Frequency Square Wave output such as the UltraMax® HID ballast, GE-MH-250-400-MAX-208-207 or similar for optimal lamp performance.

3.2.2 High Frequency

GE does not make high frequency HID ballasts due to reasons described in the Low Frequency Lamp Operation section above. However, high frequency operation is applicable for matched lamp ballast systems. Caution must be taken when designing these systems for an application to make sure that the ballast and lamp are compatible to avoid premature lamp failure and safe operation.

4 Electromagnetic Ballast Applications

4.1 Ballast Casing Designs

GE ballasts come in a variety of casings for most common lighting applications.

4.1.1 Core & Coil

Core & coil ballasts are the most popular style of EM ballast. GE's core & coil models are available for all HID lamp types, including single-, dual-, tri-, and multi-voltage designs. Core & coil ballasts are ideal for a wide variety of lighting applications, including factories, warehouses, gymnasiums and retail stores. All these GE ballasts feature precision-wound coils, ensuring even heat dissipation and the highest electrical integrity.

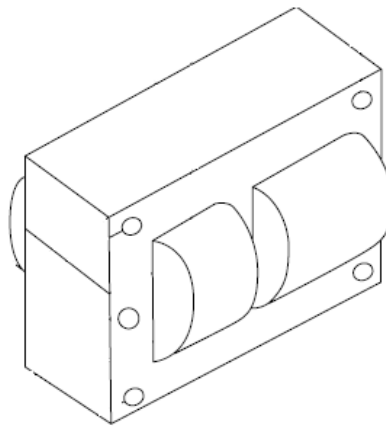

Figure 9: Core and Coil Ballast

4.1.2 F-Can

These ballasts are used primarily for indoor downlighting applications where quiet operation is essential. All the components of these ballasts are enclosed in fluorescent-style ballast cans and are thermally protected.

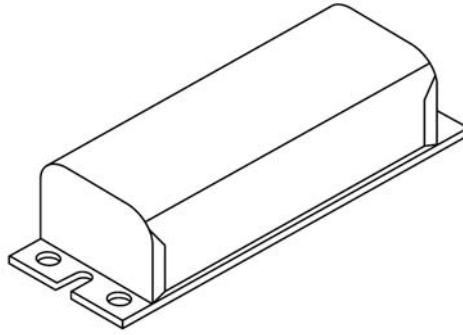

Figure 10: F-Can Ballast

4.1.3 Potted Core & Coil

GE potted core & coil ballasts are designed for applications requiring quieter or cooler operation than provided by standard coil & coil ballasts. The potting material is a sand-filled polyester which provides excellent sound-deadening and heat transfer qualities.

4.2 GE Ballast Kits

Most GE HID ballasts are sold in a kit, which contains a capacitor and an ignitor (where appropriate), which simplifies installation because the components come pre-wired and reduce labor costs.

4.2.1 Power Factor Capacitors

Power factor capacitors are used to reduce the negative effects that inductive devices have on power factor ratings. GE sells a variety of these devices which must be bought specific to the lamp and ballast combination that will be used. For maximum safety and reliability, all GE capacitors come with built-in bleed resistors and environmental safety is assured through the use of biodegradable, nontoxic (no PCBs) dielectric fluid.

Oil Filled Capacitors

GE has a comprehensive line of capacitors in metal cases (up to 520V ratings) and plastic cases (up to 400V ratings) – plus metal cases for dual-level operation. All GE capacitors are designed for 60,000 hours of continuous life. GE capacitors are normally packaged with ballasts, however, they may also be ordered separately.

Dry Capacitors

Dry capacitors do not contain oil and are manufactured with plastic casing. Plastic cases are UL rated for use up to 100°C maximum. Dry capacitors are designed and rated for AC voltages below 400V @ 50 or 60 Hz. Capacitors used with HID ballasts at voltages above 400VAC should contain interrupters, which are available through GE.

4.2.2 Ignitors

Some ballast designs require ignitors to start the lamp. Ignitors create a glow discharge in the lamp by providing a voltage high enough to ionize the gas. This glow discharge is created by a 2500 volt pulse. Once the lamp is started, the ignitor stops pulsating automatically.

Ignitors are designed to last thousands of hours. However, if the lamp has failed, or if the socket is empty, the ignitor will continue pulsing. In these situations, it is important to replace the lamp or turn off the HID fixture to preserve the ignitor's life.

Standard Ignitors are supplied with all High Pressure Sodium, Pulse Arc, and Metal Halide ballast requiring ignitors. These ballasts are supplied with the appropriate external ignitor and are to be wired within two feet of the lamp. Sometimes the ignitors can be permanently attached to or built into the ballast.

Long range Ignitors are used in situations where an ignitor must be mounted further from the lamp than is recommended for a standard ignitor. The maximum lamp to ignitor distance for these ignitors is 50 feet, which may vary depending on the type of lamp, ballast, fixture, and wiring.

Instant Restrike Ignitors generate multiple pulses to restrike lamp arc without a cool down time, after a brief power interruption has extinguished it. This requires a special lamp and is still subject to warm-up time.

Automatic Shutoff Ignitors will apply pulses for 10 to 12 minutes and then deactivate if a lamp arc cannot be initiated. This saves the on ignitor life because a standard ignitor will continue to pulse. Resetting the Automatic Shutoff ignitor is accomplished by momentarily interrupting the power to the ballast. They should not be used on unswitched circuits that cannot be reset.

Shutoff Devices is an Ignitor Accessory that can be used to convert a Standard Ignitor into an Automatic Shutoff Ignitor. The catalog lists all the different Ignitors and accessories.

5 Electronic Ballast Applications

5.1 *Pulse ratings and applicable lamps*

Electronics ballasts use a high voltage pulse (3-4kV) for lamp ignition. In order to safely handle this high voltage pulse rated sockets, wires, connectors, and lamp holders must be used. Most lamps can be used with electronic ballasts, however, probe start lamps cannot.

5.2 *Power Factor Correction*

Power factor is defined as the ratio of real power in Watts to complex power in Volt-Amperes (VA). It is always a number between 0 and 1. Power factor is significant to power generating utilities because it is a measure of what they must generate in VA to what is actually consumed in Watts. As an energy user's power factor decreases the utility has to supply more current for a given amount of real power use.

The majority of GE's ballasts are designed with Power Factor Correction circuitry to maximize the ballasts efficiency. They are sold with two types of power factor correction. The first is Normal Power Factor (NPF) correction, which produces a power factor less than 0.9. The second is High Power Factor (HPF) correction, which produce a power factor of greater than or equal to 0.9. NPF is appropriate for lower wattage products or where the aggregate ballast density in an installation is low.

5.3 Transient Protection

GE ballasts are also designed to withstand transient peaks due to variations in the line voltage. These variations in line voltage occur often in industrial areas where high-power machinery switches on and off creating large loads on the power system. Without proper protection, continued exposure to these types of fluctuation could damage the ballast. IEEE rates equipment for distance from grid and peak withstand capabilities. GE rates equipment dependent upon primary application.

5.4 Hi-Potting Ballast with Internal Transient Protection

Regulatory standards require dielectric strength testing on all ballasts to check the insulation between all live parts and all dead metal parts that are exposed or are likely to become grounded. Recent trends in ballast design have seen an increase in the use of transient protection devices incorporated within the ballast circuit. In these transient protected cases a test conflict arises in the dielectric strength test between the applied high voltage and the nature of the transient protection circuit to limit this voltage.

Typically ballasts that incorporate line transients protection do so by adding a MOV between the input leads and earth ground. This MOV restricts the maximum allowable applied voltage and therefore the maximum applied dielectric strength voltage. A new test protocol is needed for these transient protected designs. To ensure the integrity of such ballasts, a "High-pot" test is completed during manufacturing and a "Lo-pot" procedure has been developed by GE to allow OEMs to test ballasts onsite. GE has proposed that the same test procedure, which is used to test for damaged or crimped leads during installation, is adequate to validate the system assembly.

In this test, a potential of 300VDC followed by a 500VDC is applied to the ballast, with the breakdown current limited to <0.5mA. The MOV is expected to withstand the 300VDC, but if there are any crimped wires or shorts, the tester will trip. With the 500VDC test potential, the MOV is expected to clamp, tripping the tester.

The result of this test is a "pass" if the tester trips in the range of $300\text{VDC} < V_{\text{trip}} < 500\text{VDC}$, and a "failure", if the tester does not trip.

5.5 Output Short Circuit

5.5.1 HID Ballast Output Short Circuit Guide

Electronic HID Ballasts are a relatively new and exciting technology that is now available to the OEM market. Electronic HID ballasts rely on low frequency square wave output for enhanced lamp compatibility. However, this low frequency output makes the ballasts sensitive to certain types of output shorts.

Often times, incorrectly routed leads, damaged leads, fixture assembly issues, and user error cause shorts between lamp output leads (Differential Mode short), or lamp output leads and earth ground (Common Mode Short) which makes the lighting system malfunction. In the case of a short between output leads and earth ground, the ballast is instantly destroyed.

5.5.2 Differential Output Shorts (Output Lead to Output Lead)

GE ballasts are designed to withstand a short between output leads. The ballast can withstand this short circuit mode indefinitely by dropping into a low power mode when detected to protect itself. After 45-90 minutes, some ballasts shut themselves off completely. The illustration below depicts the difference between Differential Mode and Common Mode shorts.

Typical HID Ballast Illustrating Common Mode and Differential Mode

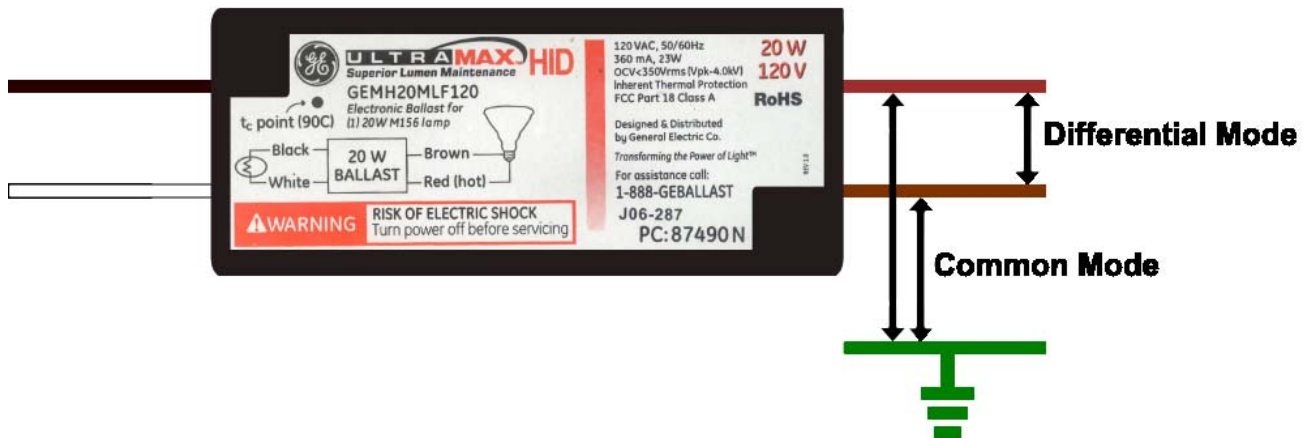

5.5.3 Common Mode Output Shorts (Output Lead to Ground)

GE Electronic ballasts cannot withstand output shorts to ground. To avoid causing an accidental output short to ground, please follow the ballast and fixture instruction sheet and installation guide carefully. Also, please avoid pinching, punching through, cutting or compressing any of the output leads during installation.

5.5.3.1 Troubleshooting and Proper Lead Routing and Protection from Shorts to Ground

If a known good lamp is not starting, one potential failure mode is a short between the output leads and earth ground. To troubleshoot this failure, do the following:

Common Mode

First turn the power off to the ballast and measure the resistance from both of the lamp socket contacts to earth ground. Under proper installation, high impedance on the order of Mega Ohms, or "Open" should be measured. If "Short", or very low impedance is measured, then there is a short between the lamp output of the ballast and ground due to improper installation or defective fixture wiring. This is a Common Mode failure and the ballast will need to be replaced and is not under warranty.

To repair the "Short-to-ground" or Common Mode failure, one should recheck the entire fixture assembly, ballast and lamp focusing particularly on wire routing, loose wire-nuts, damaged or frayed conductors, cut or nicked insulation on ballast or fixture leads and pinched leads. Please be sure to thoroughly check all of the aforementioned and review the installation guide before installing a new ballast.

Differential Mode

In a similar manner, one can check for a Differential Mode failure by again shutting the power off and measuring the resistance between both lamp output leads. Under proper installation, high impedance on the order of Mega Ohms, or "Open" should be measured. If "Short", or very low impedance is measured, then it is likely that there is a short between the two leads. In this instance, the ballast will still function but the short must be found and removed. Review the installation guide and recheck all of the ballast wiring, again paying close attention to wire routing, loose wire-nuts, damaged or frayed conductors, cut or nicked insulation and pinched leads.

5.6 Remote Mounting

In some lighting applications it is desirable to mount HID ballasts away from the actual light source to reduce audible noise, or simply for a more consolidated design. In these instances, ballasts are often mounted together in a room, or panel box. To ensure reliability and safe operation, special attention must be given to ballast spacing, distance to lamp, wire gauge and heat dissipation.

When grouping ballasts together, ballast must be staggered if mounted in multiple rows. Also, it is imperative that the ballasts not be mounted to metal, or other conductive materials.

The distance the ballast will be mounted from the lamp and the wire gauge is also important for remote mounting. Many lighting systems require an ignitor to start the lamp. In these systems, the maximum ballast to lamp distance is determined by the ignitor spec. Often times, a long-range ignitor can be purchased to extend this distance.

Note: Increasing wire diameter does not necessarily improve ignition performance for remote mounting. Often times an increase in wire diameter creates larger capacitance between wires, which further attenuates the signal.

Other lamp systems do not rely on an ignitor to start the lamp. In these systems, the ballast to lamp distance is limited by voltage drop created due to resistance in long wiring. Ballast to lamp distances are provided in the GE Ballast Catalog. If these guidelines are not paid attention to, the voltage drop may cause the lamp not to start.

5.7 Dimming Applications

Some GE ballasts now feature dimming control for customers who wish to reduce the light level produced by their lamps when the area they are lighting is unoccupied, or where full light level is not desired. The ballasts are designed to drop up to nearly half of its lamp's rated power consumption, which translates into large energy savings to some of our customers. Note that lamp performance criteria such as CCX, CCY, CCT and CRI may vary from specification when lamps are used at lower than full-wattage mode.

There are two general classes of HID dimming systems. In bi-level dimming, HID lamps are run in a low mode of reduced lamp power when less light is required. Lamps are then switched to 100% lamp power (high mode) when full illumination is needed. The other common class of dimming systems is called "continuous" and allows for users to select wattage, and thus, provides complete light control.

A typical electronic ballast dimming wiring diagram is shown below.

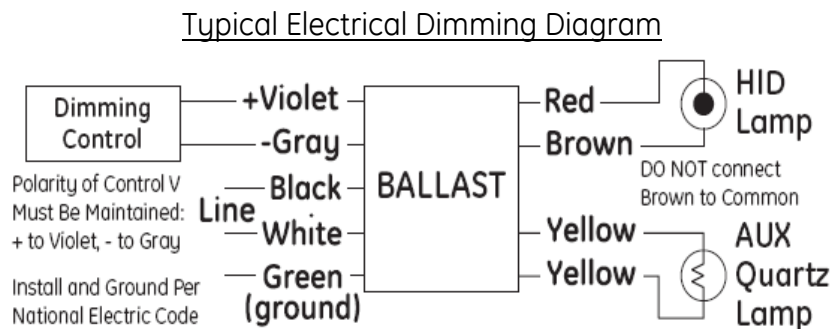

GE engineers have implemented features to overcome a few of the negative effects of operating lamps at lower than their rated wattage level, and ensure long lamp life.

5.7.1 Power Up at 100%

GE ballasts are designed to power up at 100% of their rated power regardless of their current dimming setting. GE engineers have learned, through a large amount of research into GE and competitors lamps, that operating lamps during start-up at a dimmed light level may adversely affect lamp life. As a result, the ballasts are programmed to ignore dimming commands for the first 15 minutes they are on and then resume normal dimming operation.

5.7.2 Full Light Level Cycling

Through related research, GE engineers have also learned that 15 minutes of full power is required once every 24 hours to ensure long lamp life. GE HID dimming ballasts are programmed with a timer, which overrides dimmer commands once every 24 hours and powers the lamps to full power for 15 minutes.

5.7.3 Minimum Dimming Level

GE HID dimming ballasts are designed to operate lamps at particular wattages to avoid premature lamp failure. Most lamps are capable of dimming to 50-60% of their full power operating wattage. The tables below describe the wattage operation levels that can be achieved by most lamp types. When designing a dimming system, the effects of line voltage fluctuation, ballast wattage control and lamp operating voltage variation within the range of the ANSI specifications must be considered so that no combination of factors cause the lamp power to go below the specified limits. The table below describes the minimum dimming wattage of GE HID lamps commonly used in dimming applications.

Multi-Vapor®, PulseArc®, Watt-Miser®, StayBright™, ConstantColor®CMH® metal halide Lamps:
ChromaFit™ HPS retrofit Lamps:

Lamp Power Rating (Watts)	Minimum Lamp Operating Power (Watts)
150*	97
175	97
250	138
320	138
350	175
360	200
400	200
750	375
1000	500
1500	750

*Applies only to Wattmiser-type QMH lamps.

Lucalox® High Pressure Sodium Lamps:

Lamp Power Rating (Watts)	Minimum Lamp Operating Power (Watts)
35	13
50	18
70	25
95	34
100	35
110	39
125	44
150	53

200	70
215	76
250	88
310	109
360	126
400	140
750	263
1000	350

6 Temperature effects on Lamp and Ballast

6.1 Heat

A ballast, like any other electrical device, generates heat during normal operation. Planning for maximum heat dissipation with proper fixture design, installation planning and ballast selection will minimize the possibility of a heat-related problem arising. Excessive temperature will have an adverse effect on ballast life.

6.2 Normal Temperature Limits:

F-Can Ballasts

Maximum case temperature: 90°C

Weatherproof Ballasts

Maximum case temperature: 90°C

Core & Coil Ballasts and Potted Core and Coil Ballasts

Insulation: Class 180°C

Maximum coil temperature: 165°C (measured by change of resistance method)

6.3 Thermal Protection

All F-Can ballasts sold by GE are equipped with built-in automatic resetting internal thermal protection as a standard feature. Other ballast types may be available with thermal protection as an option. Whenever a ballast with thermal protection is used, it is imperative that the fixture/ballast/lamp combination be heat tested under actual or simulated installation conditions to assure that the ballast will not cycle.

The resetting thermal protector functions as a thermostat, which will open and temporarily deactivate the ballast when it exceeds the permissible temperature. The ballast will continue to cycle until the cause of overheating is eliminated. If the cause is external, the ballast will resume normal operation after abnormal conditions are eliminated. To attain normal ballast life, the maximum coil temperature of the ballast should not exceed the rating of the insulation system. A temperature increase of 10°C results in a 50% reduction of ballast life.

6.4 Low Ambient Starting Temperature

As temperatures drop, less and less vaporized gas is available within the arc tube of a high intensity discharge lamp, thereby causing an increase in the open circuit voltage required to initiate an arc in the lamp, until a point is reached where the lamp cannot be started. The minimum temperature at which any ballast will provide reliable starting is listed with the lamp characteristics section. Low ambient temperatures will also result in a slight increase in the warm-up period of any type of high intensity discharge lamp.

6.5 Other Environmental Conditions

Ballasts should be protected from weather, moisture, or other abnormal atmospheric conditions, unless specifically designed for use under adverse conditions.

7 Standard and Regulatory Ratings

7.1 UL, CSA, FCC, IEC, NEMA, etc.

UL - Underwriter Laboratories, Inc is a non-profit safety certification organization. UL creates standards for materials, products, components and systems with safety concerns. They also maintain a list of 66 laboratories, testing and certification facilities where companies can test their products.

UL provides two different approvals for ballasts. "UL Listed" is a rating for stand-alone finished products that may or may not be used inside another "UL Listed" product. "UL Recognized" (UR) is a rating for a component of a system and typically is not a stand-alone product and must be used as a part of a larger assembly or system. HID core and coil ballasts are typically Recognized components.

The UL Bench Top Temperature Rise test operates a HID ballast on a bench-top to note the rise in temperature over ambient. The lower the thermal rise, the better the bench-top thermal rise code. The code is shown as 1029x, with x being A, B, C... A being the best (lowest temperature rise) rating. HID ballast also have Insulation Class ratings, which indicate the ability of the ballast to withstand very high temperatures. Class H (180°C) and the newest Class N (200°C), extend the thermal operating range of the ballast.

FCC-Federal Communications Commission is a USA governmental agency to monitor and police the radio frequency spectrum. Ballasts fall under CFR47, Part 18 (Lighting) in two categories: Class

A for normal Commercial and Industrial applications, and a more restrictive Consumer Class B rating.

CSA – Canadian Standards Association is the UL equivalent in Canada. Similar to UL, they create safety and performance standards for goods to be sold in Canada.

IEC – International Electrotechnical Commission is a global organization that creates and publishes international standards for electrical, electronic and related technologies. IEC promotes cooperation between nations in standardization and related matters. IEC based Safety Agencies include VDE, SEMKO, KEMA and many other organizations that all test to the same set of IEC Standards, and all honor the Safety Mark of their neighbors in the European Community. IEC standards are also used in most other parts of the world.

NEMA – National Electrical Manufacturers Association is a United States based association, which sets standards used in a wide range of electrical products. For lighting, NEMA is the organization through which the industry (composed of ballast, lamp and fixture manufacturers) can bring a voice to Congress and the Department of Energy (DoE) and help draft new legislation leading to energy efficient solutions. NEMA also seeks to regulate its members and to protect US lighting and other markets by setting high standards for product performance and reliability.

NOM – Normas Oficiales Mexicanas, is the Mexican equivalent to the United States UL.

GB - Guobiao Standard, is the accepted regulatory standard for Asian countries. It is equivalent to the IEC.