

ConstantColor™ CMH™

Ceramic Metal Halide Lamps

Single Ended G12

Product Information for Original Equipment Manufacturers

LAMP TECHNOLOGY

ConstantColor™ CMH lamps combine the HPS technology (providing stability, efficiency & uniformity) and the Metal Halide Technology (providing bright white quality light) to produce highly efficient light sources with good colour rendering and consistent colour performance through life. This is achieved by using the ceramic arc tube material from the Lucalox™ lamp, which minimises the chemical changes inside the lamp through life. When combined with the halide doses used in Arcstream™ Metal Halide lamps then the quality and stability of the dose maintains the colour consistency. Hence the name ConstantColor™ CMH. Metal halide lamps, traditionally made with quartz arc tubes, are prone to colour shift through life and lamp-to-lamp colour variation. Some of the dose, e.g. sodium, (an important component of metal halide lamps), can migrate through quartz to cause colour shift and loss of light through life. The ceramic arc tube resists this material loss, can be manufactured to tighter tolerances and withstands a higher temperature to provide a more constant colour.

FEATURES

- Consistent colour over life
- Colour uniformity lamp to lamp
- Bright light – in a very compact size
- Excellent colour rendition
- Improved reliability due to 3 part design
- Up to 97 LPW efficacy
- Up to 15,000 Hr life
- UV control
- Easy retrofit for Quartz Metal Halide lamps
- Two colour temperatures 3000K and 4200K



SINGLE ENDED FORMAT

Single ended Ceramic Metal Halide lamps are made to provide symmetrical beam distribution using the axial configuration of the discharge arc. A variety of beam angles are possible and adjustable beam control can be built into the luminaire.

This compact lamp shape enables luminaire size to be minimised and the bi-pin lamp base enables easy changing with front access.

APPLICATION AREAS

- Retail
- Offices
- Stage/Studio
- Architectural lighting
- Display Cabinet
- Hotels



SPECIFICATION SUMMARY*

Ordering information

Description	Wattage	Colour	Product code
CMH20/T/UVC/U/830/G12	20	3000K	21691
CMH35/T/UVC/U/830/G12	35	3000K	20099
CMH35/T/UVC/U/842/G12	35	4200K	92141
CMH70/T/UVC/U/830/G12	70	3000K	20005
CMH70/T/UVC/U/942/G12	70	4200K	20013
CM150/T/UVC/U/830/G12	150	3000K	20012
CM150/T/UVC/U/942/G12	150	4200K	20014

General	Units	20W	35W	35W	70W	70W	150W	150W
		3000K	3000K	4200K	3000K	4200K	3000K	4200K
Product code		21691	20099	92141	20005	20013	20012	20014
Nominal wattage	W	20	35	35	70	70	150	150
Format		Single Ended						
Bulb type		T4.5	T4.5	T4.5	T6	T6	T6	T6
Bulb diameter	mm	14.5	14.5	14.5	19	19	19	19
Bulb material		UVC Quartz						
Bulb finish		Clear						
Arc Gap	mm	3.35	4.7	4.3	7.4	5.5	10.5	10.0
Base		G12						

Operating Conditions

Burning Position	Universal
Luminaire characteristics	Enclosed

Notes:

- 1) Note that the lamp voltage inside the luminaire should not deviate by more than 5V from the bare lamp voltage in free air.
- 2) Thermal protection required
- 3) Data supplied on conventional ballast. Improved ratings on electronic ballasts.
- 4) Data for 35W 4200K is based on operation from an electronic ballast. Lamps can run on conventional ballasts with a small reduction in performance.
- 5) 20W designed for operation only from an electronic ballast.

Electrical Characteristics

Lamp power	W	20	39	39	72	72	145	145
Lamp voltage	V	90	90	90	90	90	93	93
Lamp current	A	0.226	0.5	0.5	0.98	0.98	1.85	1.85
Max. Ignition Voltage	kV	5						
Min. Ignition Voltage	kV	3.5						
Extinction voltage	%	90 (Max.)						
(% of rated input voltage)								

* The specification contains data about typical performance on 50 Hz sine wave ballast at nominal power (35W 4200K data for operation on typical electronic ballast). Actual values may depend on ballast and application.

SPECIFICATION SUMMARY*

Photometric characteristics

		20W	35W	35W	70W	70W	150W	150W
		3000K	3000K	4200K	3000K	4200K	3000K	4200K
Product code		21691	20099	92141	20005	20013	20012	20014
100 hrs Lumens	lm	1700	3400	3150	6200	6300	14000	13000
Typical Lumen change with burning position - vertical to horizontal	lm				100 - 150			
Typical voltage change with burning position - vertical to horizontal	V				8			
Correlated Colour Temperature K		3000	3000	4200	3000	4200	3000	4200
Chromaticity X		0.455	0.435	0.375	0.435	0.375	0.435	0.375
Chromaticity Y		0.400	0.400	0.370	0.400	0.370	0.400	0.370
Colour Rendering Index	Ra	80+	80+	88	80+	90+	80+	90+
Luminous efficacy	lm/W	85	87	80	86	88	97	90
Base					G12			

Starting and Warm-up Characteristics¹

Time to start (at 25 °C)	sec.				< 2			
Time to start - Cold box test at -30 °C	sec.				< 15			
Hot restart time	minutes	< 3			15			
Warm-up time to 90% lumen output	minutes	1.2	2	2	3	3	3	3

¹Typical values (actual values are ballast and ignitor dependent)

Through life Performance²

Lumen maintenance at 40% rated life (mean lumens) %		72	78	85	72	76	81	74
Average rated life	hours	7500	10000	6000**	15000	15000	12000	12000

²Life data measured in Vertical Base up position. Performance can be greatly increased in horizontal position.

Maximum Operating temperatures^{***}

Maximum allowed bulb temperature (horizontal, orientation, thermocouple attached above burner)	°C	500	500	500	500	500	650	650
Maximum pinch temperature (vertical base up orientation)	°C	350	350	350	350	350	350	350

* The specification provides typical performance data for 35W & 70W operating from a 50Hz mains sinewave supply at nominal power. Actual values depend on ballast, supply voltage and application 20W to be used only with an electronic ballast - see later for additional notes on electronic ballast requirements.

**Initial vertical life claim at launch (4K lamps). Testing in progress to full lamp life.

*** Temperatures above which lamp performance or reliability is impaired. Additionally, voltage rise when operated in luminaire should not exceed 5V

DIMENSIONS

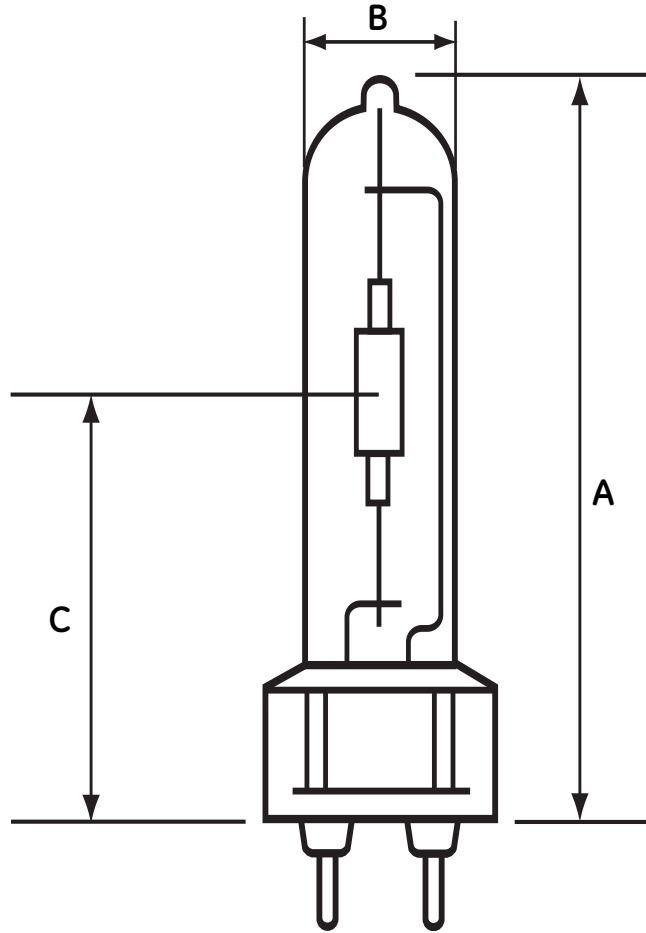

Watt	20W	35W	35W	70W	70W	150W	150W
	3000K	3000K	4200K	3000K	4200K	3000K	4200K
Product code	21691	20099	92141	20005	20013	20012	20014
Dimensions							
A (mm)	90	90	90	90	90	100	100
B (mm)	14.5	14.5	14.5	19	19	19	19
C (mm)	56	56	56	56	56	56	56

SPECTRAL POWER DISTRIBUTION

Spectral Power Distribution curves are given in the following diagram

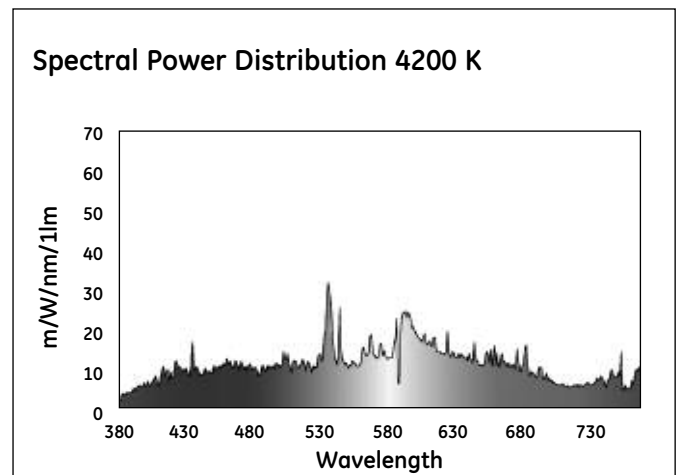
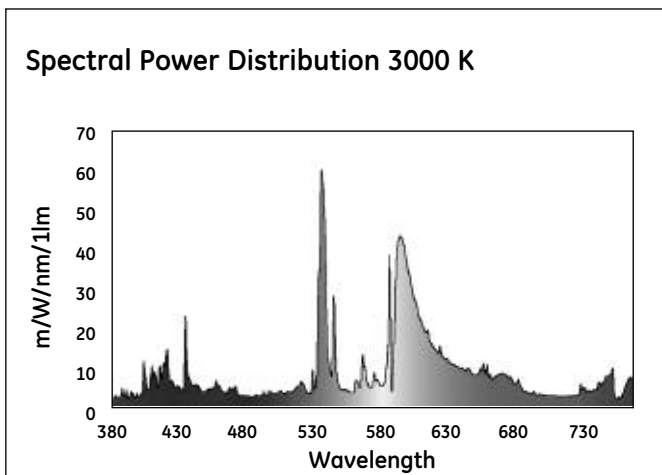

DISTRIBUTION OF LUMINOUS INTENSITY

The following diagrams show polar light intensity curves for lamp cap-up position

Vertical plane polar intensity curve

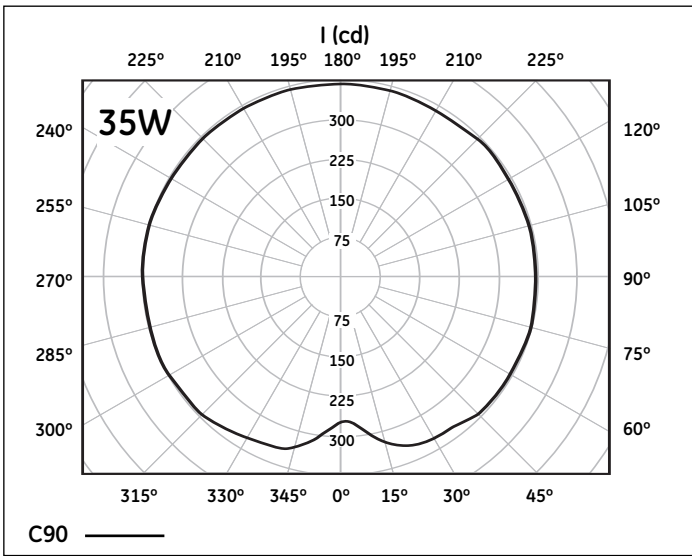

Horizontal plane polar intensity curve

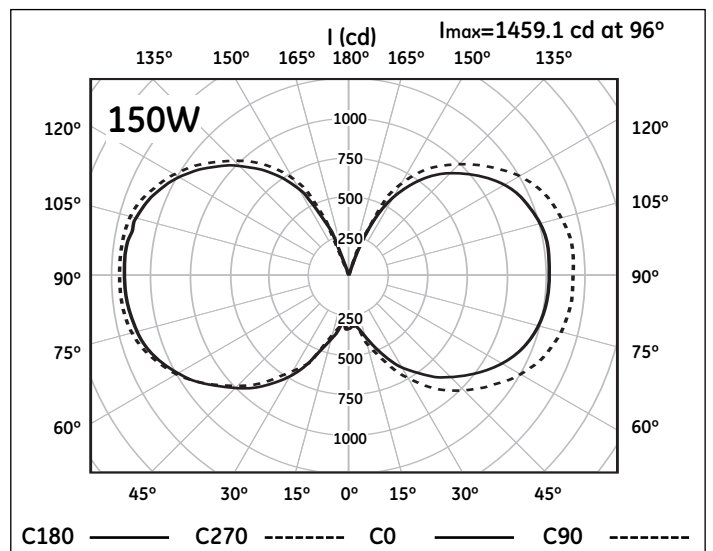
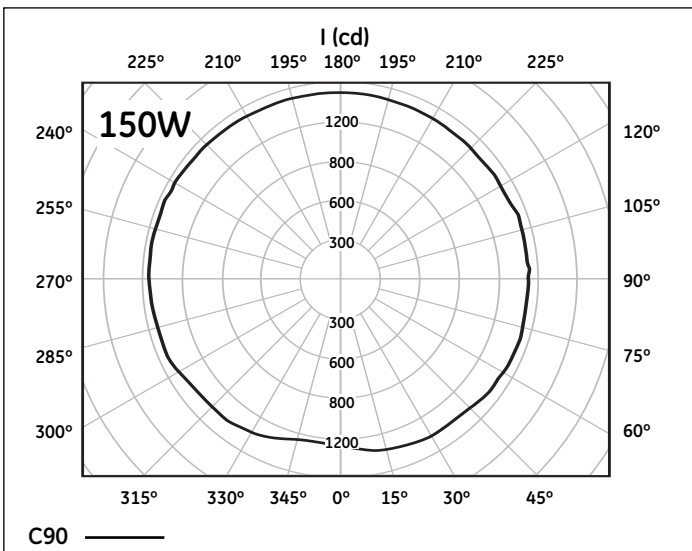
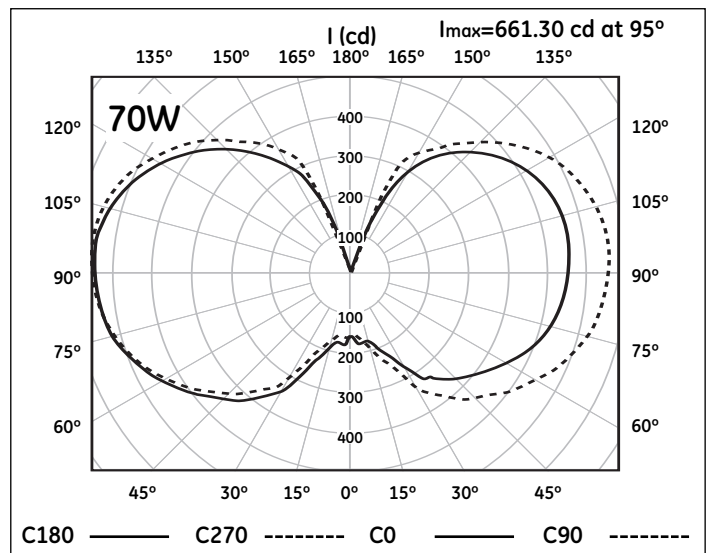
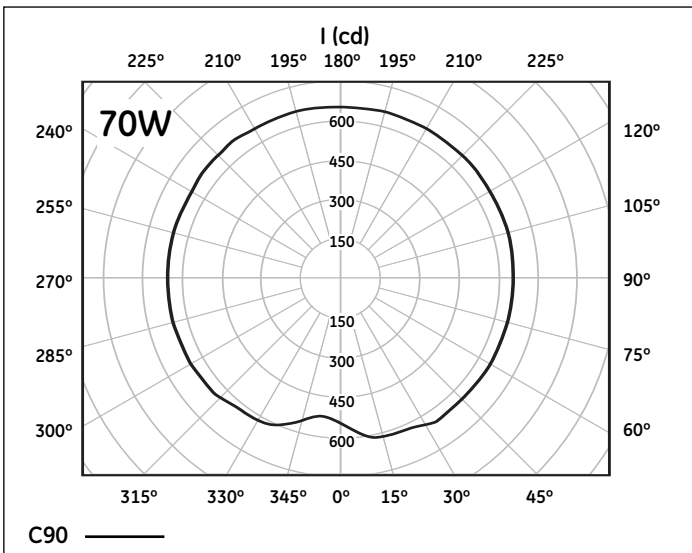
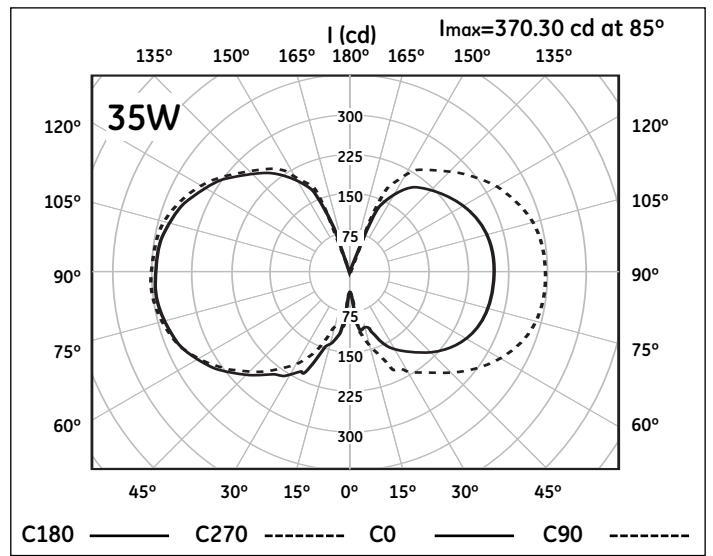

LAMP LIFE

The tables and graphs show the mortality curve and Lumen maintenance curve of statistically representative batches of lamps operated under controlled conditions of 7 hours per start. The declared lamp life is the median life, which is when 50% of the lamps from a large sample batch would have failed. Lamp life in service will be affected by a number of parameters, such as supply voltage variation, switching cycle, operating position, mechanical vibration, luminaire design and control gear. The information is intended to be a practical guide for comparison with other lamp types. The determination of lamp replacement schedules will depend upon the acceptable reduction in illuminance and the relative costs of spot and group replacement.

Note: The representative curves are taken in Vertical Base Up position. Life performance can greatly increase in Horizontal Burning position.

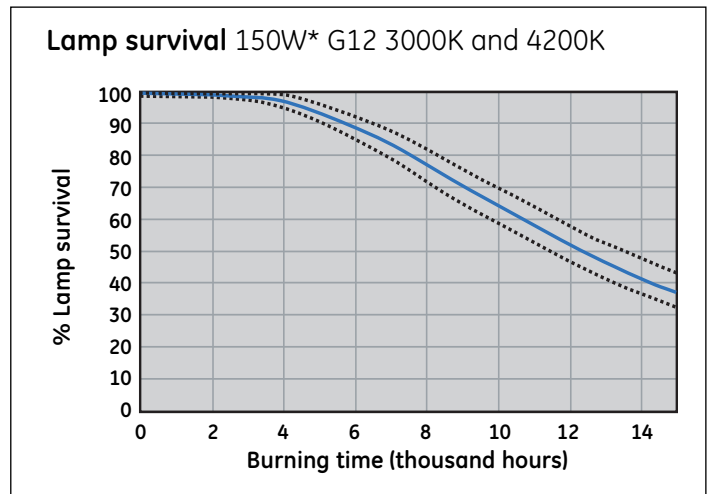
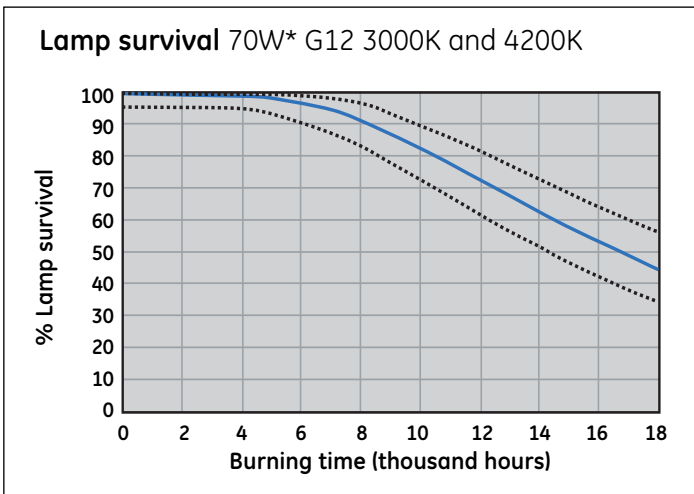
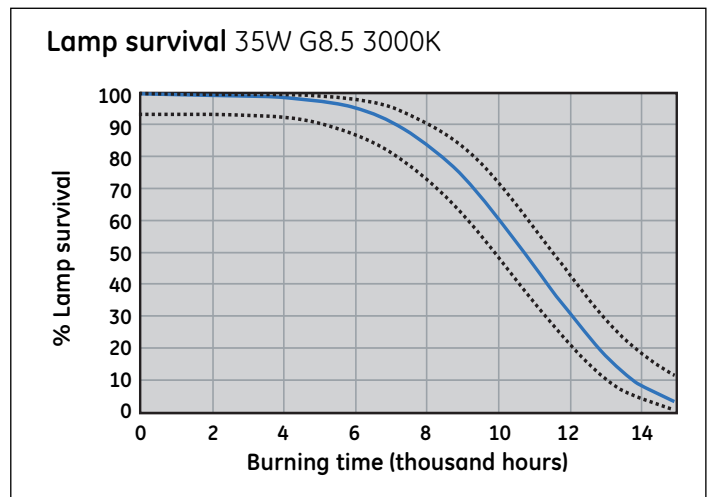
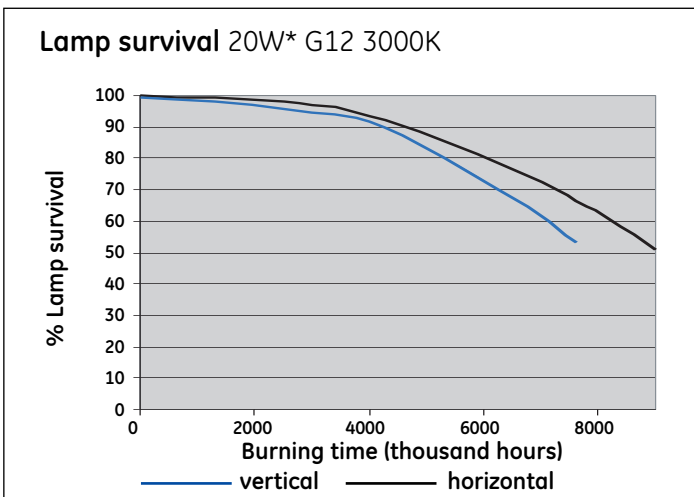

LUMEN MAINTENANCE

Lumen maintenance graph shows how the luminous output decreases throughout life. All metal halide lamps experience a reduction in light output and a very slight increase in power consumption through life. Consequently there is an economic life when the efficacy of the lamp falls to a level at which is better to replace the lamp and restore the illumination. Where a number of lamps are used within the same area it may be well worth considering a group lamp replacement programme to ensure uniform output from all the lamps. Curves are representing 7 hours per start cycle, less frequent starting will improve lumen maintenance.

Note: The representative curves are taken in Vertical Base Up position. Lumen maintenance improves greatly when lamps burned in Horizontal Burning position.

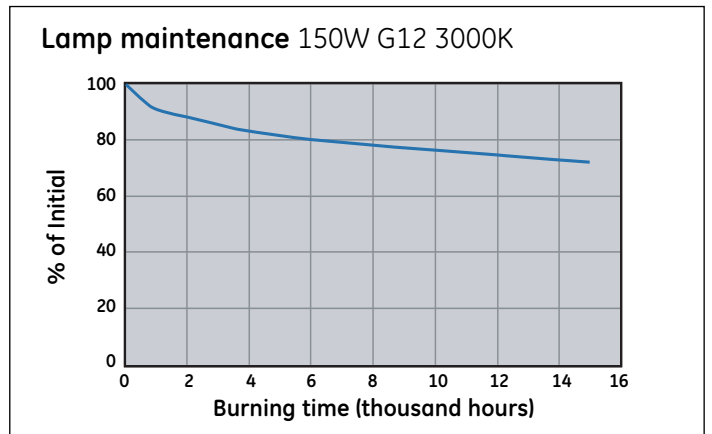
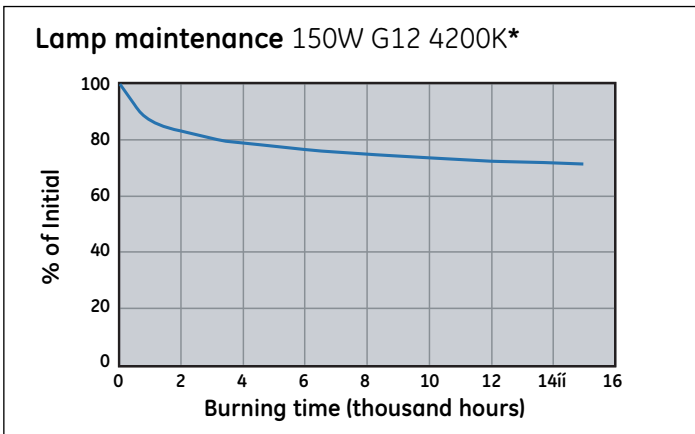
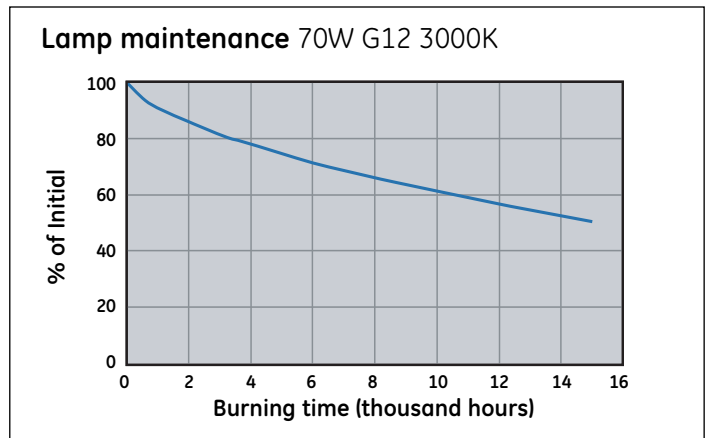
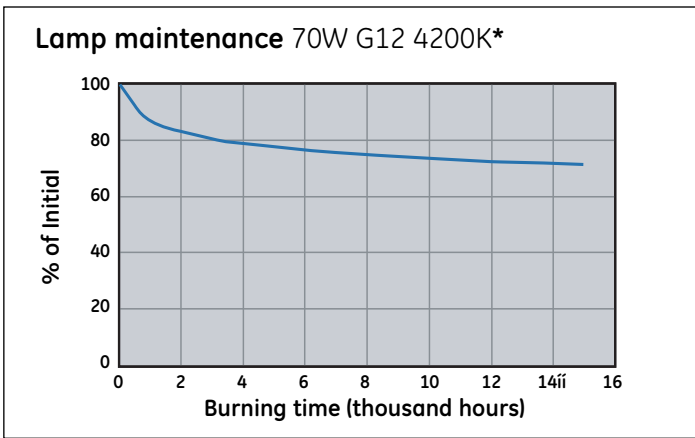
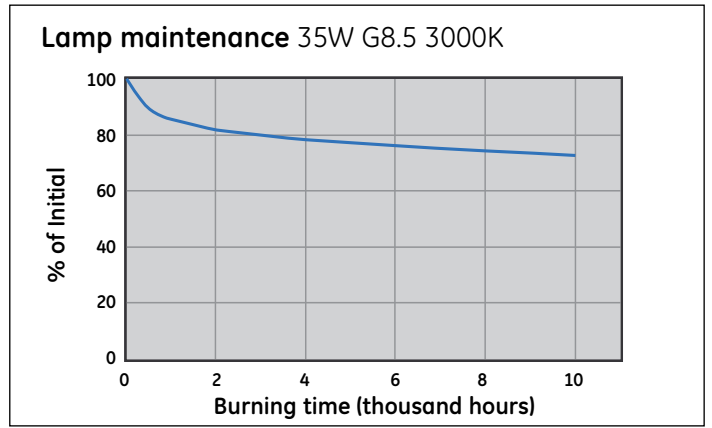
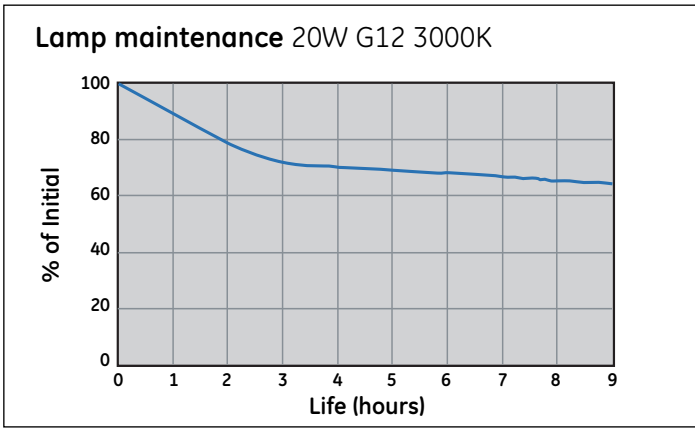

*Provisional data

WARM-UP CHARACTERISTICS

During the warm-up period immediately after starting, lamp temperature increases rapidly and mercury and the metal halides evaporate within the arc-tube. The lamp current and voltage will stabilise in less than 4 minutes. During this period the light output will increase from zero and the colour will approach the correct visual effect as each metallic element becomes vaporised.

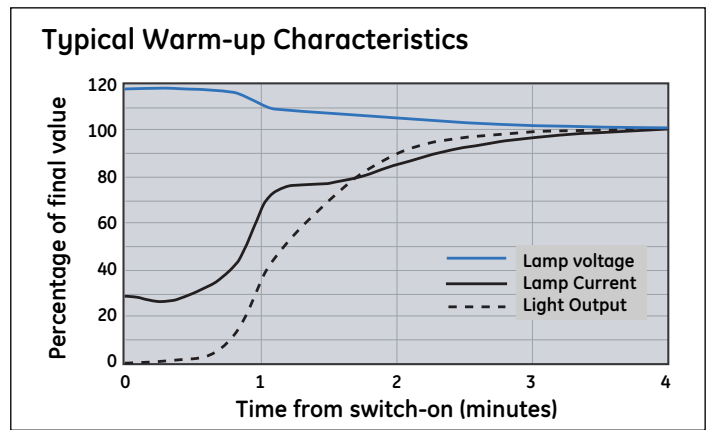

SUPPLY VOLTAGE SENSITIVITY

The line supply voltage applied to the control gear should be as close to rated nominal as possible. Lamps will start and operate at 10% below rated supply voltage but this should not be considered as a normal operating condition. In order to maximise lamp survival, lumen maintenance and colour uniformity, supply voltage and rated ballast voltage should be within $\pm 3\%$. Supply variations of $\pm 5\%$ are permissible for short periods only. Where supply voltage variation is likely to occur the use of electronic control gear should be considered as this type of equipment is normally designed to function correctly for a voltage range of 200-240V.

DIMMING

The dimming of metal halide lamps is not normally recommended. Changes in lamp power alter the thermal characteristics of the lamp and will result in lamp colour shift and possible reduction in lamp survival.

FLICKER

With conventional ballasts there will be a line frequency (50 Hz) flicker from ConstantColor™ CMH lamps as with all other discharge lamps. For example a 150W single-ended lamp has a flicker value of approximately 1.5 %. Normally this is not of concern, but, where visual comfort and performance is critical, the use of electronic control gear should be considered. Suitable electronic ballasts for ConstantColor™ CMH lamps provide switched dc operation in the 70-200 Hz range and eliminate perceptible flicker. A horizontally operated ConstantColor™ CMH lamp, such as a Double-Ended type, will also produce noticeably less flicker.

END OF LIFE CONDITIONS

The principal end of life failure mechanism for CMH lamps is arc tube leakage into the outer jacket. At the high operating temperatures inside the arc-tube, the corrosive dose material gradually corrodes the arc tube wall and can eventually cause leakage after a long period of time. Arc-tube leakage into the outer jacket can be noticed by a sudden significant lumen drop and a perceptible color change (the color usually turns green).

The above situation is often coupled with the so-called rectification phenomena. When this occurs one of the leadwires will act as a cathode changing the electrical characteristic of the discharge to be asymmetric ("rectified"). Due to the increased cathode losses rectification can cause overheating of the ballast. Therefore any ballast used with ConstantColor™ CMH lamps must conform to the IEC 61167 standard and incorporate thermal protection against overheating.

It is good practice with lamps that are operated virtually continuously to introduce a switching once every 24 hours. Lamps with one electrode failing often will not restart and thus are detected and can be replaced. See Fusing Recommendations.

LUMEN DEPRECIATION

All metal halide lamps experience a reduction in light output and a very slight increase in power consumption through life. Consequently there is an economic life when the efficacy of the lamp falls to a level at which is better to replace the lamp and restore the illumination. Where a number of lamps are used within the same area it may be well worth considering a group lamp replacement programme to ensure uniform output from all the lamps.

END OF LIFE CYCLING

A condition can exist whereby after a long period of time the lamp voltage rises to a value above the voltage supplied by the control gear. In such a case the lamp extinguishes, but on cooling the required ignition voltage falls to within that provided by the ignitor, so the lamp restarts. As the lamp re-heats the lamp extinguishes again.

Normally cycling is an indication that the end of lamp life has been reached but it can also be due to lamps operating above the recommended temperatures. The lamp voltage should never be more than 5V higher when installed in the luminaire compared with the same lamp operated in free air. For a good luminaire design, lamp voltage increase should be limited to 3V. See Timed or Cut-out Ignitors.

As good practice, if a failed lamp is noticed it is worth changing as soon as possible, because longer cycling can damage the ignitor.

UV AND DAMAGE TO SENSITIVE MATERIALS

The wall of the bulb, which is produced with specially developed 'UV Control' material, absorbs potentially harmful high energy UV radiation emitted by the ceramic arc-tube.

The use of UV control material together with an optically neutral front glass cover allows the lamp to significantly reduce the risk of discolouration or fading of products. When illuminating light-sensitive materials or at high light levels, additional UV filtration is recommended. Luminaires should not be used if the front glass is broken or missing. It is recommended that a safety interlock switch is incorporated into the luminaire to prevent operation when the luminaire is opened.

Although PET determines limits of human exposure to lamp UV, the risk of fading of mechanism due to UV can be quantified by a Damage Factor and a Risk of Fading. The risk of fading is simply the numerical product of the illuminance, exposure time and damage factor due to the light source.

Finally the selection of luminaire materials should take into consideration the UV emission. Current UV reduction types on the market are optimised for UV safety of human eye and skin exposure. However, luminaire materials may have different wavelength dependent response functions. Designers must take account of emission in each of the UV-A, UV-B and UV-C spectral ranges as well as material temperatures when designing luminaires.

Typical values for UV-A, UV-B and UV-C range radiation can be found in the table below.

Lamp type		20W 3000K	35W 3000K	35W 4200K	70W 3000K	70W 4200K	150W 3000K	150W 4200K
UV-PET Performance $\mu\text{W} / (\text{cm}^2) / 500\text{LUX}$								
UV C	220-280nm	0.028	0.0367	0.020	0.014	0.011	0.017	0.010
UV B	280-315nm	0.018	0.0467	0.040	0.006	0.009	0.011	0.008
UV A	315-400nm	4.535	10.360	13.870	6.980	9.800	7.552	9.752
UVC/UVB		2.17	0.786	0.509	2.365	1.321	1.583	1.188
UVB/UVA		0.004	0.005	0.003	0.001	0.009	0.001	0.001
E _{eff}		0.043		0.034	0.015	0.014	0.020	0.013
PET (h) $\pm 10\%$		20	15	26	54	64	43	65
Risk Group	IESNA RP-27.3-96	Exempt	Exempt	Exempt	Exempt	Exempt	Exempt	Exempt

INFORMATION ON LUMINAIRE DESIGN

BALLASTS

ConstantColor™ CMH operate from the same type of ballast as conventional quartz technology metal halide lamps of the same nominal power. IEC 61167 makes it mandatory to use either a thermally protected ballast or an equivalent protection device in the circuit. This safety device will protect the circuit at end of lamp life should partial rectification occur due to electrode imbalance or arc tube failure. This requirement applies to both ceramic and quartz arc tube metal halide lamps.

STRAY MAGNETIC FIELD OF CONVENTIONAL BALLAST

When designing a luminaire one should take into account that fixture layout (the position and distance of lamp and ballast) could influence lamp performance as well.

Conventional ballasts generally have stray magnetic fields around them, and if a lamp is placed within this field it can lead to “bowing” of the arc in the discharge tube. Since ceramic arctube is much more rigid, than quartz arctubes, this bowing can lead to arctube rupture and cause the lamp to fail early.

Therefore in fixtures where the ballast is placed near the lamp the use of magnetic shielding is suggested. Another possibility is to use electronic ballasts, that eliminate the need for ignitors, simplify wiring and have smaller stray field.

CONTAINMENT REQUIREMENT

ConstantColor™ CMH lamps operate above atmospheric pressure, therefore a very small risk exists that the lamp may shatter when the end of life is reached. Though this failure mode is unlikely, containment of shattered particles is required as prescribed by IEC 61167.

Single-ended lamp should only be used in a suitable enclosed luminaire with front cover glass capable of containing the fragments of a lamp should it shatter .

CONTROL GEAR AND ACCESSORIES

Electronic Ballasts

A range of GE electronic ballasts have been introduced to complement the ConstantColor™ Ceramic Metal Halide lamps.

Power controlled electronic ballasts suitable for operation of Ceramic Metal Halide lamps are available from various gear manufacturers.

Advantages are:

- Good regulation against supply voltage variation
- Improved lamp colour consistency
- Elimination of lamp flicker
- Reduced weight of control gear
- Reduced electrical power losses
- Ballast noise reduced/eliminated
- Single piece compact unit
- Reduced wiring complexity in the luminaire



Features

- Integral version with open terminals for embodiment into luminaire
- Remote version with terminal cover and cable strain relief for location outside the luminaire
- 50,000 hours service life under the specified conditions
- Reduced power consumption compared to electromagnetic circuits
- Reduced component count and simplified wiring compared to electromagnetic circuits
- Rapid and controlled power run-up
- Lamp life maximised by square-wave current and constant lamp power
- Excellent lamp colour stability throughout life
- Automatic lamp failure shut-down
- Timed restart after mains voltage interruption
- Immune to mains voltage variations

General Information

Watts	Volts	Description	Mounting	Weight	Pack Qty	Product Code
20	220-240	BLS/E/20W/CMH	Integral	190 g	12	13032
20	220-240	BLS/E/20W/CMH/R	Remote	230 g	12	13034
35	220-240	BLS/E/35W/CMH	Integral	215 g	12	13035
35	220-240	BLS/E/35W/CMH/R	Remote	230 g	12	13036
70	220-240	BLS/E/70W/CMH	Integral	300 g	12	13040
70	220-240	BLS/E/70W/CMH/R	Remote	310 g	12	13047
150	220-240	BLS/E/150W/CMH	Integral	430 g	12	13050
150	220-240	BLS/E/150W/CMH/R	Remote	445 g	12	13053

System Performance		20W	35W	70W	150W
System Power	W	23.5	43	78	159
System Efficacy	lm/W	72	79	79	88
Lumens*	lm	1700	3400	6200	14000
Lamp Power	W	20	39	72	146
Lamp Efficacy	lm/W	85	87	86	96
Lamp Voltage Range	V	70...125	70...125	70...125	70...125

Data shown relates to 3000K products. Please see lamp data sheets for performance of equivalent 4200K rated products.

Operating Characteristics		20W	35W	70W	150W
Mains Voltage	V	220...240	220...240	220...240	220...240
Mains Current	A	0.10	0.18	0.33	0.69
Mains Frequency	Hz	50...60	50...60	50...60	50...60
Power Factor		> 0.95	> 0.95	> 0.95	> 0.95
Allowed Mains Voltage Range	V	198...264	198...264	198...264	198...264
Ignition Voltage*	kV	< 2.5	< 2.5	< 2.5	< 2.5
Lamp Operating Frequency	Hz	150	150	150	150
Max Cable Capacitance	pF	1000	3000	3000	3000
Max Lamp Distance**	m	10	25	25	25
Ambient Temperature Range	°C	-20...+50	-20...+50	-20...+50	-20...+50
Maximum Case Temperature	°C	75	75	75	80
Thermal Cut-off on PCB	°C	110	110	110	110

* If a hot lamp or no lamp is detected the ballast will attempt to start the lamp after one minute, if not successful further attempts are made up to a maximum of 4 times in 5 minute cycles, then if not successful the ballast will shut-down. The ballast is reset automatically by a supply interruption.

** Typical value if cable capacitance is below the specified limit

Dimensions

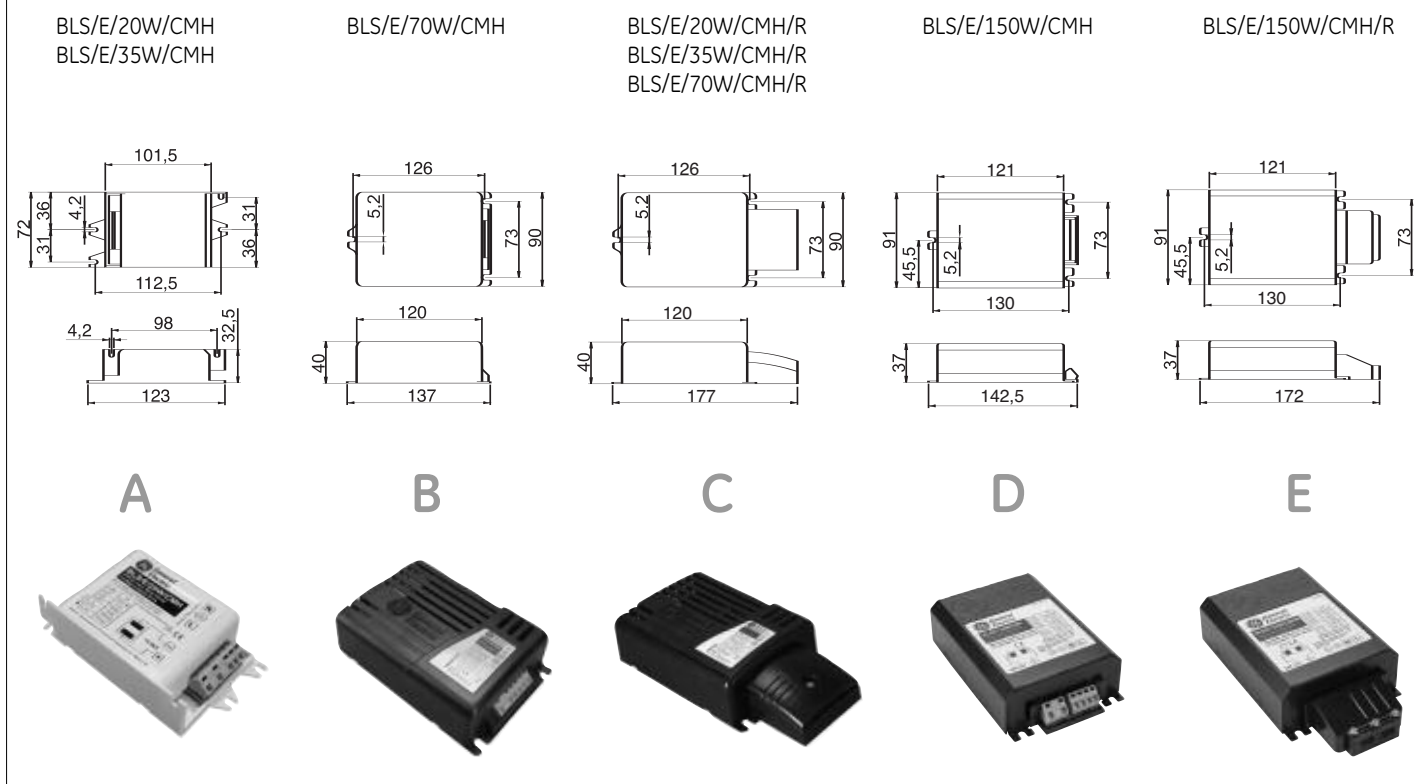

Circuitry

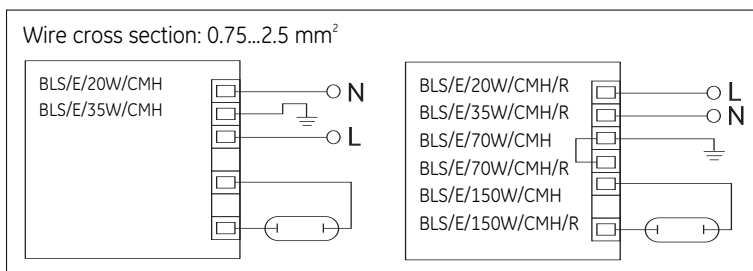

The ballasts comply with the relevant parts of the following standards:

- RFI suppression EN 55015
- Harmonics EN 61000-3-2
- Immunity EN 61547
- Safety EN 60926/EN 60928/EN 61347
- Performance EN 60927/EN 60929

SUPERIMPOSED IGNITORS

In most installations Ceramic Metal Halide lamps are operated on conventional ballast using superimposed ignitors. These ignitors generate starting pulses independently from the ballast and they need to be placed close to the lamp (usually within the luminaire). Typical circuit diagram is displayed below:

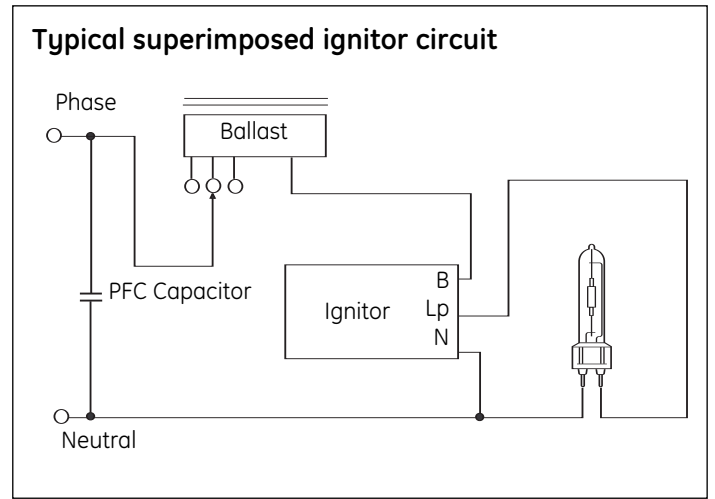

SUITABLE IGNITORS

Suitable high-energy (superimposed) ignitors are listed below recommended by gear manufacturers. Check with your supplier for their current range of ignitors. Lamp re-starting under warm lamp conditions can take up to 15 minutes.

Suitable ignitors with a warm restart of less than 15 minutes include the following, with the list not being exhaustive:

Maker	Products				
APF	SP23				
BAG Turgi	NI 150 SE	NI 150 SE-TM20	MZN 150 SE-C	NI 400 LE/3.5 A	NI 400 LE/3.5 A-TM20
ERC	AZ A 1.8	AZ P 1.8	AZ P 3.0	AZ P 1.8 T3	AZ P 3.0 T3
Helvar	L-150	LSI-150T20			
Magnetek/May & Christe	ZG 0.5	ZG 2.0	ZG 2.0D	ZG 4.5 D	
Parry/Parmer	PAV400	PCX400	PXE100		
Philips	SU20S				
Thorn	G53459	G53498	G53476	G53504.TB	
Tridonic	ZRM 1.8-ES/B	ZRM 2.5-ES/B	ZRM 4.5-ES/B	ZRM 6-ES/B	ZRM 2.5-ES/D
Vossloh-Schwabe	Z 150	Z 150 K	Z 150 A10	Z 150 K A10	Z 250

IMPULSER IGNITORS

Impulser type ignitors use the ballast windings as a pulse transformer and can only be used with a matched ballast. Always check with the ballast and ignitor supplier that the circuit components are compatible. Ignitors must be capable of generating a pulse voltage and pulse width greater than the minimum specified for ConstantColor™ CMH lamps.

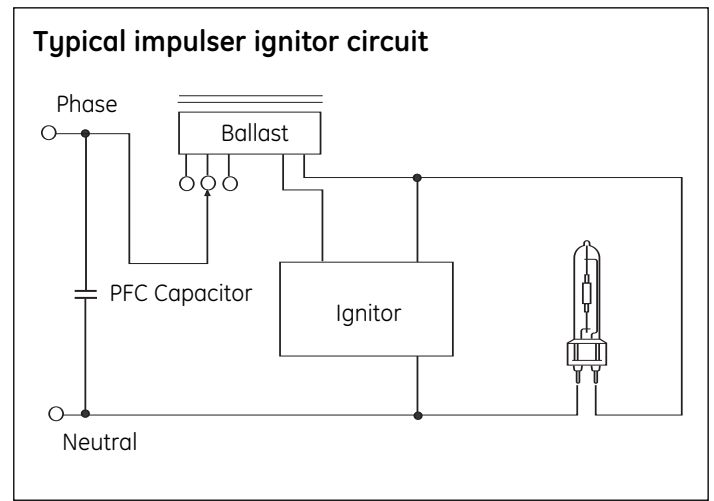

OTHER IGNITOR RELATED CONSIDERATIONS

Timed or Cut-out Ignitors

The use of a 'timed' or 'cut-out' ignitor is not a specific requirement for ConstantColor™ CMH lamps but it is a good optional safety feature worth considering to protect the ignitor from overheating and to prolong its life. If used, the timed period must be adequate to allow lamps to cool and restart as described in the previous section. A period of 10-15 minutes continuous or intermittent operation is recommended before the ignitor automatically switches off. Timed ignitors specifically offered for High-Pressure Sodium lamps where the period of operation is only about 5 minutes are not suitable for ConstantColor™ CMH lamps.

Hot Re-strike

All ratings re-strike within 15 minutes following a short interruption in the supply. Hot re-strike may be achieved using a suitable ignitor. Actual re-strike time is determined by the ignitor type, pulse voltage and cooling rate of the lamp.

Warm Re-starting

Because of the ceramic materials and the vacuum jacket ConstantColor CMH™ lamps lose their heat slowly. It is possible with low energy (impulser) ignitors to reach the required breakdown voltage, but not sustain a thermionic discharge. Under these conditions the lamp can remain warm and be prevented from cooling to a temperature at which the arc can be re-established. To avoid this, turn off the power supply for approximately fifteen minutes or change to a suitable ignitor from the list given in the superimposed ignitor section.

Fusing Recommendations

For a very short period immediately after switch-on, all discharge lamps can act as a partial rectifier and the ballast may allow higher than the normal current to flow. In order to prevent nuisance fuse failure the fuse ratings must take account of this.

See relevant information on national installation requirements for High Intensity Discharge lighting circuits.

Single fusing is recommended which gives added protection for the end-of-life condition when partial rectification can also occur.

HBC or MCB (type 3 or 4) fuse ratings for single and multiple lamp installations

Number of Lamps	1	2	3	4	5	6
20W Fuse Rating (A)						
35W Fuse Rating (A)	4	4	4	4	4	4
70W Fuse Rating (A)	4	4	4	6	6	10
150W Fuse Rating (A)	4	6	10	10	16	16

SAFETY WARNINGS

The use of these products requires awareness of the following safety issues:

WARNING

- Risk of electric shock - isolate from power supply before changing lamp
- Strong magnetic fields may impair lamp performance, and in the worst case could lead to lamp rupture

Use only in **ENCLOSED FIXTURES** to avoid the following:

- Risk of fire
- A damaged lamp emits UV radiation which may cause eye/skin injury
- Unexpected lamp shattering may cause injury, fire or property damage

CAUTION

- Risk of burn when handling hot lamp
- Lamp may shatter and cause injury if broken
- Arc tube fill gas contains Kr-85

Always follow the lamp operation and handling instructions supplied.



Please visit us on the web at www.GELighting.com
and General Electric are both register trademarks of
the General Electric Company
Biax™ and 2D™ are registered trademarks

© General Electric Company 2005

GE Lighting is constantly developing and improving its products. For this reason, all product descriptions in this brochure are intended as a general guide, and we may change specifications time to time in the interest of product development, without prior notification or public announcement. All descriptions in this publication present only general particulars of the goods to which they refer and shall not form part of any contract. Data in this guide has been obtained in controlled experimental conditions. However, GE Lighting cannot accept any liability arising from the reliance on such data to the extent permitted by law.

CMH Single Ended G12 Product Information for OEMs April 2005